

DESCRIPTION

The SR-FB3 is designed to be used to suspend the Line Array Speaker.
Only 1 speaker can be suspended using the SR-FB3.

SPECIFICATIONS

Applicable Speaker	SR-H3S, SR-H3L, SR-H2S, SR-H2L
Finish	Steel plate, white, paint
Weight	630 g (1.39 lb)
Product Composition	Suspension bracket ×1, Pull-back bracket ×1, Spacer plate ×1
Accessory	Suspension bracket mounting bolt (hex bolt M5 × 40 (with washer)) ×2, Pull-back bracket mounting bolt (hex bolt M5 × 25 (with washer)) ×2

APPEARANCE

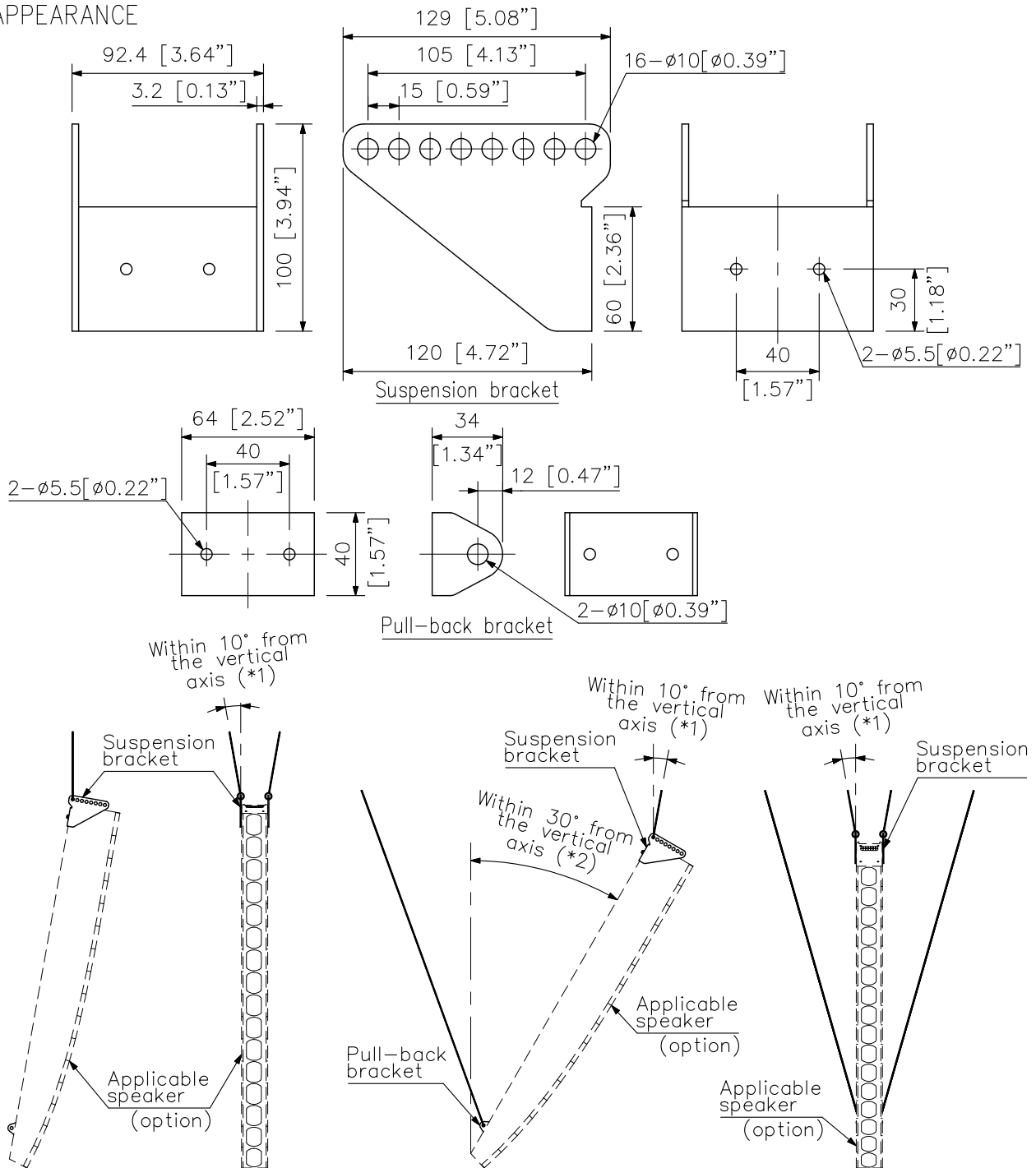

Two-wire suspension method

Four-wire suspension method

(*1) When suspending the speaker, the angle of the suspension wires must be within 10° from the vertical axis.

(*2) The inclination angle of the speaker's rear surface must be within 30° from the vertical axis.

UNIT:mm SCALE:1/3 Mounting example (scale: 1/20)