



OPERATING INSTRUCTIONS

CONFERENCE SYSTEM

TS-780 SERIES

TS-780 (CENTRAL UNIT)

TS-781 (CHAIRMAN UNIT)

TS-782 (DELEGATE UNIT)

TS-773 (MICROPHONE)

TS-774 (MICROPHONE)

YR-780-2M (2 m EXTENSION CORD)

YR-780-10M (10 m EXTENSION CORD)

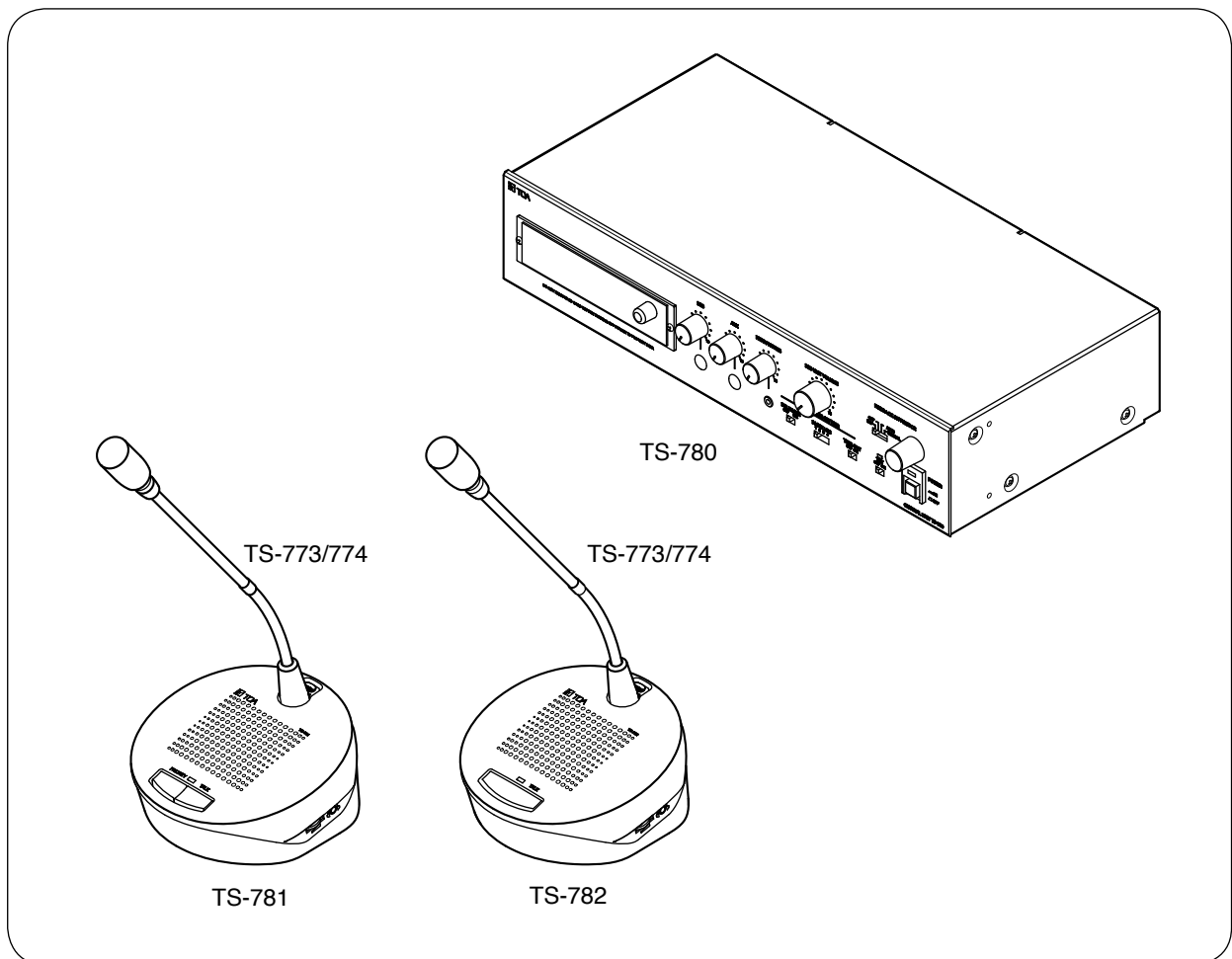

Thank you for purchasing TOA's Conference system.

Please carefully follow the instructions in this manual to ensure long, trouble-free use of your equipment.

TABLE OF CONTENTS

1. SAFETY PRECAUTIONS	3
2. GENERAL DESCRIPTION	5
3. FEATURES	5
4. NOMENCLATURE AND FUNCTIONS	6
4.1. TS-780 Central Unit	6
4.2. TS-781 Chairman Unit and TS-782 Delegate Unit	8
5. FUNCTION SETTINGS	10
5.1. Delegate Unit Restriction Function	10
5.2. Automatic Mic-Off Function	11
5.3. Test Function	11
5.4. FBS (Feedback Suppressor) Function	12
6. OPERATING CHAIRMAN AND DELEGATE UNITS	14
6.1. Making Speech	14
6.2. Making Priority Speech (Chairman Unit TS-781 Only)	15
7. RECORDING	16
7.1. Using the TS-780 Central Unit's Built-in MP3 Recorder	16
7.2. Using an External Recording Equipment	40
8. INSTALLATION AND CONNECTION	42
8.1. Installation Procedures	42
8.2. Connection Example	43
8.3. Basic System Installation and Adjustment	44
9. IF USING MULTIPLE CENTRAL UNITS	48
10. IF MOUNTING A CENTRAL UNIT IN A RACK	49
11. SPECIFICATIONS	50
11.1. TS-780 Central Unit	50
11.2. TS-781 Chairman Unit and TS-782 Delegate Unit	51
11.3. TS-773 and TS-774 Microphones	51
11.4. YR-780-2M 2 m Extension Cord and YR-780-10M 10 m Extension Cord	51

1. SAFETY PRECAUTIONS

- Before installation or use, be sure to carefully read all the instructions in this section for correct and safe operation.
- Be sure to follow all the precautionary instructions in this section, which contain important warnings and/or cautions regarding safety.
- After reading, keep this manual handy for future reference.

Safety Symbol and Message Conventions

Safety symbols and messages described below are used in this manual to prevent bodily injury and property damage which could result from mishandling. Before operating your product, read this manual first and understand the safety symbols and messages so you are thoroughly aware of the potential safety hazards.



WARNING

Indicates a potentially hazardous situation which, if mishandled, could result in death or serious personal injury.



CAUTION

Indicates a potentially hazardous situation which, if mishandled, could result in moderate or minor personal injury, and/or property damage.



WARNING

When Installing the Unit

- Do not expose the unit to rain or an environment where it may be splashed by water or other liquids, as doing so may result in fire or electric shock.
- Use the unit only with the voltage specified on the unit. Using a voltage higher than that which is specified may result in fire or electric shock. (TS-780 only)
- Do not cut, kink, otherwise damage nor modify the power supply cord. In addition, avoid using the power cord in close proximity to heaters, and never place heavy objects -- including the unit itself -- on the power cord, as doing so may result in fire or electric shock. (TS-780 only)
- Avoid installing or mounting the unit in unstable locations, such as on a rickety table or a slanted surface. Doing so may result in the unit falling down and causing personal injury and/or property damage. (TS-780 only)
- Since the unit is designed for in-door use, do not use it outdoors. When it gets wet with rain, there is a danger of electric shock.

When the Unit is in Use

- Should the following irregularity be found during use, immediately switch off the TS-780's power, disconnect the power supply plug from the TS-780's AC outlet and contact your nearest TOA dealer. Make no further attempt to operate the unit in this condition as this may cause fire or electric shock.

- If you detect smoke or a strange smell coming from the unit.
- If water or any metallic object gets into the unit
- If the unit falls, or the unit case breaks
- If the power supply cord is damaged (exposure of the core, disconnection, etc.) (TS-780 only)
- If it is malfunctioning (no tone sounds.)
- To prevent a fire or electric shock, never open nor remove the unit case as there are high voltage components inside the unit. Refer all servicing to qualified service personnel.
- Do not place cups, bowls, or other containers of liquid or metallic objects on top of the unit. If they accidentally spill into the unit, this may cause a fire or electric shock.
- Do not touch a power supply plug during thunder and lightning, as this may result in electric shock. (TS-780 only)
- The apparatus shall be connected to a mains socket outlet with a protective earthing connection. (TS-780 only)
- The socket-outlet shall be installed near the equipment and the plug (disconnecting device) shall be easily accessible. (TS-780 only)
- Do not insert nor drop metallic objects or flammable materials into the speaker openings in the unit's cover as this may result in fire or electric shock. (TS-781/782 only)

CAUTION

When Installing the Unit

- Never plug in nor remove the power supply plug with wet hands, as doing so may cause electric shock. (TS-780 only)
- When unplugging the power supply cord, be sure to grasp the power supply plug; never pull on the cord itself. Operating the unit with a damaged power supply cord may cause a fire or electric shock. (TS-780 only)
- When moving the unit, be sure to remove its power supply cord from the wall outlet. Moving the unit with the power cord connected to the outlet may cause damage to the power cord, resulting in fire or electric shock. When removing the power cord, be sure to hold its plug to pull. (TS-780 only)
- Avoid installing the unit in humid or dusty locations, in locations exposed to the direct sunlight, near the heaters, or in locations generating sooty smoke or steam as doing otherwise may result in fire or electric shock.

When the Unit is in Use

- Contact your TOA dealer as to the cleaning. If dust is allowed to accumulate in the unit over a long period of time, a fire or damage to the unit may result. (TS-780 only)
- If dust accumulates on the power supply plug or in the wall AC outlet, a fire may result. Clean it periodically. In addition, insert the plug in the wall outlet securely. (TS-780 only)
- Switch off the power, and unplug the power supply plug from the AC outlet for safety purposes when cleaning or leaving the unit unused for 10 days or more. Doing otherwise may cause a fire or electric shock. (TS-780 only)

Applicable to Central unit, Conference unit*

This equipment is compliant with Class A of CISPR 32. In a residential environment this equipment may cause radio interference.

* Collective name of the following 2 models:
TS-781 Chairman Unit and TS-782 Delegate Unit.

2. GENERAL DESCRIPTION

The TS-780 Series conference system is designed for quick and easy installation and storage. The system can be installed by merely connecting conference units* to the TS-780 Central unit.

* Collective name of the following 2 models: TS-781 Chairman Unit and TS-782 Delegate Unit.

3. FEATURES

- Conference speech can be amplified by simply connecting the Chairman and Delegate units to the Central unit.
- Up to 64 conference units can be connected per Central unit. (32 units per line x 2 lines.)
- Up to 3 Central units and up to 192 conference units can be connected per system.
- Optional 2-meter and 10-meter extension cables allow wiring suitable to local installation conditions.
- Either the TS-773 or TS-774 Microphone can be used with the TS-781 Chairman unit and the TS-782 Delegate unit. TS-773 is a standard gooseneck microphone and TS-774 is a Long gooseneck microphone.
- Because the microphone for both the Chairman and Delegate units is detachable, both units can be stored without taking up much space.
- Test function allows easy confirmation of connections between conference units.
- The number of simultaneously operable Delegate units can be limited using the delegate unit restriction function. (Can be set to 0 – 4 units.)
- Even if the speaker forgets to turn off his or her microphone after speech completion, the Automatic Mic-Off function automatically switches off the microphone after a preset duration. (settable to OFF or 30 seconds)
- Conference contents can be recorded using a built-in MP3 recorder unit or an external recording equipment.

4. NOMENCLATURE AND FUNCTIONS

4.1. TS-780 Central Unit

[Front]

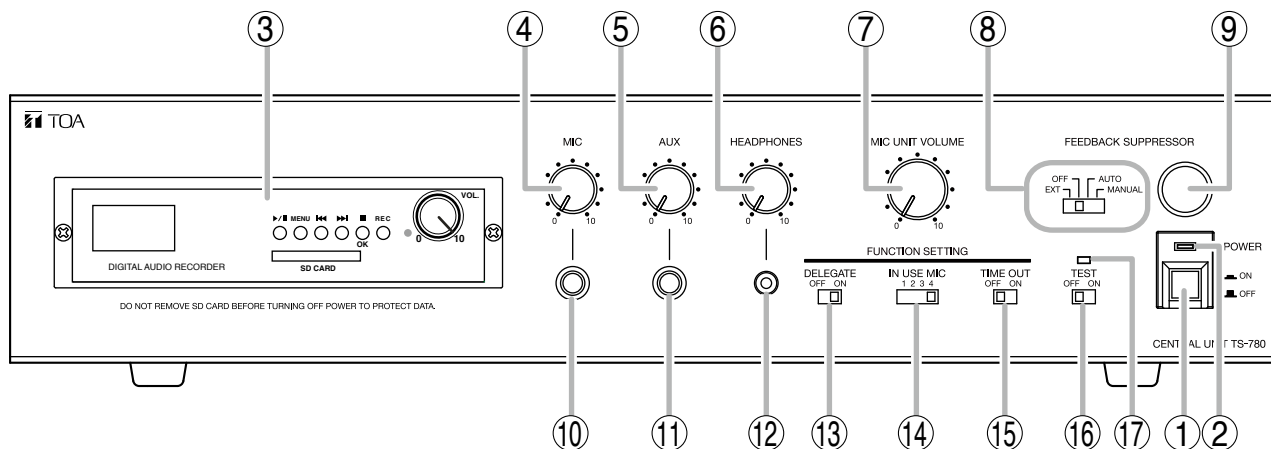

1. Power switch [POWER]

Power is switched on and off with each depression of this switch.

2. Power indicator [POWER]

Lights when the Power switch (1) is set to the ON position.

3. MP3 Recorder unit

Performs recording and playback of the conference contents using the SD card. (Refer to p. 16 "Using the TS-780 Central Unit's Built-in MP3 Recorder.")

4. Microphone volume control [MIC]

Adjusts the volume of the microphone connected to the Microphone input terminal (10).

5. AUX volume control [AUX]

Adjusts the volume of equipment connected to the AUX input terminal (11).

6. Headphones volume control [HEADPHONES]

Adjusts the volume of the headphones connected to the Headphones input terminal (12).

7. Conference unit volume control [MIC UNIT VOLUME]

Adjusts the volume of the conference unit's built-in speaker.

8. Feedback suppressor switch [FEEDBACK SUPPRESSOR]

Performs operation settings of the Feedback suppressor (FBS).

9. Feedback suppressor manual control

Sets a filter point when the FBS is operated in manual mode.

10. Microphone input terminal [MIC]

Connects to a microphone. (600 Ω, -60 dB*, unbalanced)

11. AUX input terminal [AUX]

Connects to a CD or cassette deck. (10 kΩ, -20 dB*, unbalanced)

12. Headphones output terminal [HEADPHONES]

Connects to headphones. (Mini jack)

13. Delegate unit ON/OFF switch [DELEGATE ON OFF]

Sets action of the delegate unit.

OFF: Speech can be initiated from the chairman unit only, but not from the delegate units.

ON: Speech can be initiated from both the chairman unit and delegate unit.

14. In-use delegate unit number selector [IN USE MIC]

Sets the number of delegate units that can be used simultaneously.

15. Automatic mic-off setting switch [TIME OUT]

It is possible to set the conference unit's microphone to be automatically turned off after speech completion.

16. Test switch [TEST]

This switch is intended for testing purposes during installation.

Setting this switch to the ON position turns on the microphones of all conference units.

17. Test indicator

Lights when the Test switch is set to the ON position.

* 0 dB = 1 V

[Rear]

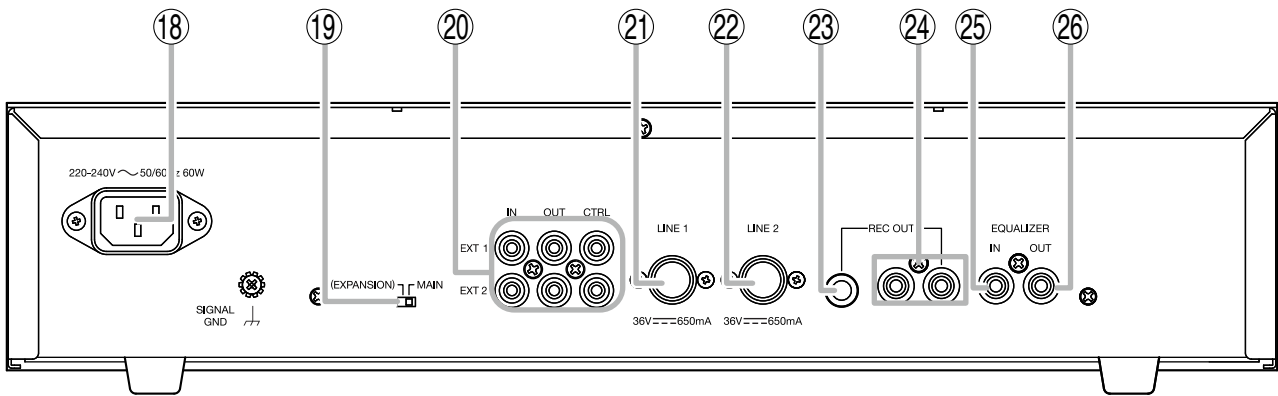

18. AC inlet

Connects to the supplied power cord.

19. Expansion switch [EXPANSION/MAIN]

Used when expanding the Central unit.

Set this switch to the EXPANSION position if expanded.

20. Expansion connection terminals [IN/OUT CTRL, EXT 1/2]

Connect to the Central unit(s) to be expanded.

21. LINE 1 connection terminal [LINE 1]

Connects to the conference unit. Up to 32 conference units can be connected per line.

22. LINE 2 connection terminal [LINE 2]

Connects to the conference unit. Up to 32 conference units can be connected per line.

23. Recording output terminal [REC OUT]

10 k Ω , -20 dB*, unbalanced, phone jack.
Connects to a recording equipment.

24. Recording output terminals [REC OUT]

10 k Ω , -20 dB*, unbalanced, RCA jack.
Connect to a recording equipment.

25. Equalizer input terminal [EQUALIZER IN]

10 k Ω , 0 dB*, unbalanced, RCA jack.
Connects to the output terminal of equalizer.

26. Equalizer output terminal [EQUALIZER OUT]

10 k Ω , 0 dB*, unbalanced, RCA jack.
Connects to the input terminal of equalizer.

* 0 dB = 1 V

4.2. TS-781 Chairman Unit and TS-782 Delegate Unit

[TS-781 Top]

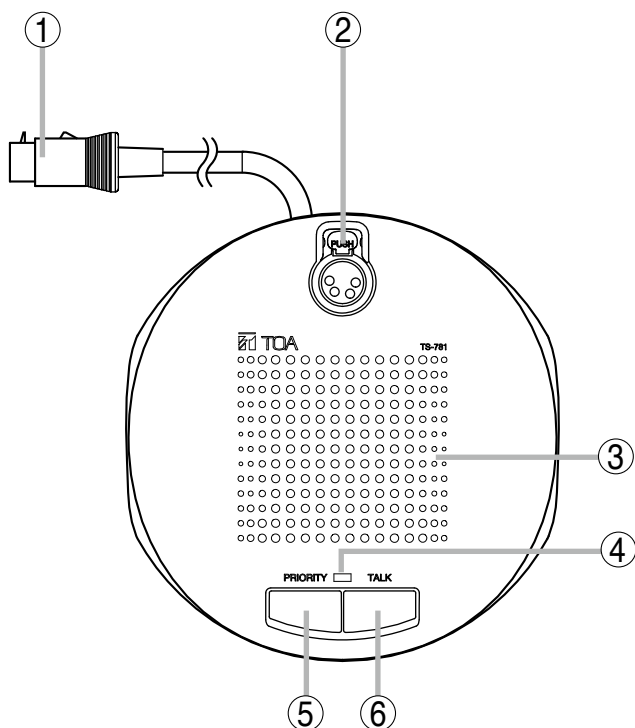

[TS-782 Top]

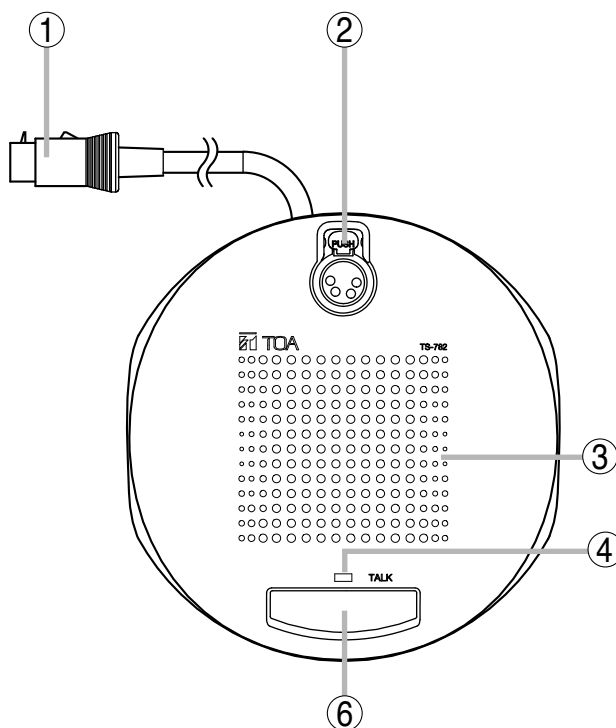

1. Line connection cord

Connect this cord to the Line Connection terminal of the Central unit or that of the next preceding linked conference unit.

Tip

Press the plug's lock/release button when connecting or removing the cord.

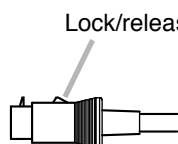

2. Microphone connection connector

Connects to the TS-773 or TS-774 Microphone.

3. Speaker

Outputs other speakers' voices. Adjust the volume with the TS-780 Central unit's Conference Unit volume control. The built-in speaker is temporarily disabled while speech is made using this unit.

4. Microphone in-use indicator

Lights when the microphone is on.

5. Priority key [PRIORITY] (TS-781 only)

While this key is pressed, the microphone in-use indicator remains lit, allowing priority speech to go through. In this case, no other delegate units can be used. Pressing this key causes a single tone chime to sound at the remaining conference units.

6. Talk key [TALK]

Press this key to speak. The microphone in-use indicator lights. Press this key again to turn off the microphone. The microphone in-use indicator goes off.

[TS-781/TS-782 Right Side]

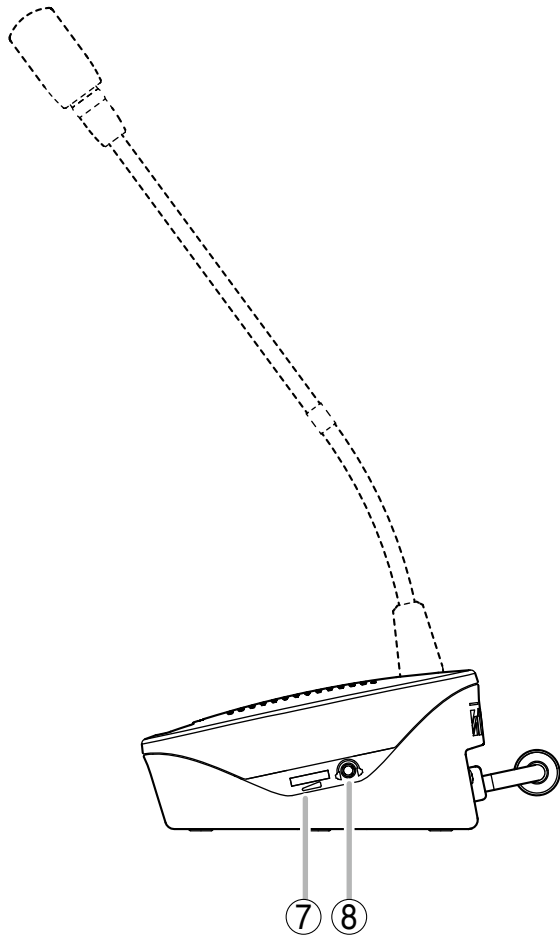

[TS-781/TS-782 Left Side]

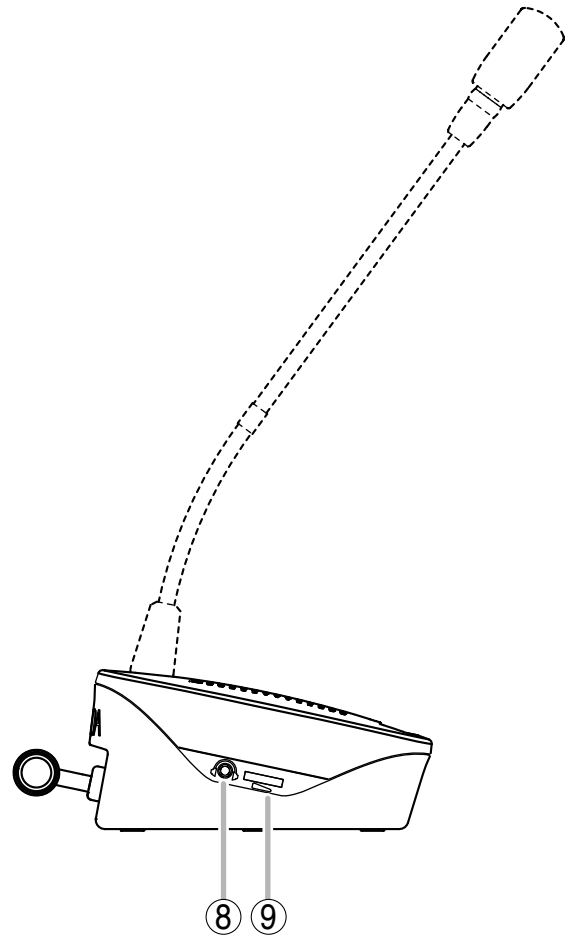

7. Speaker and headphones volume control

Simultaneously adjusts the sound output volume of the built-in speaker and the headphones connected to the adjacent Recording/Headphones output terminal (8).

**8. Recording/Headphones output terminals
[HEADPHONES]**

Connect to recording equipment or headphones. No sound is output from the internal Speaker (3) while either or both terminals are in use.

9. Headphones volume control

Adjusts the sound output volume of the headphones connected to the adjacent Recording/Headphones output terminal (8).

[TS-781/TS-782 Rear]

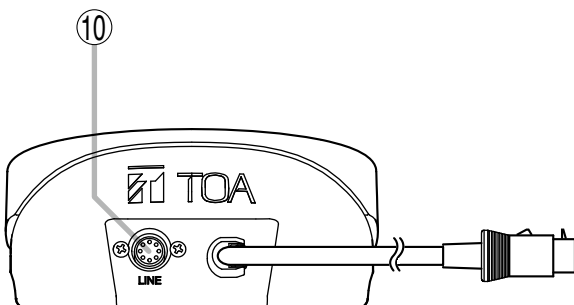

10. Line connection terminal [LINE]

Connect the next linked conference unit's line connection cord to this terminal.

5. FUNCTION SETTINGS

5.1. Delegate Unit Restriction Function

Using the TS-780 Central unit's delegate unit ON/OFF switch (DELEGATE) and in-use delegate unit number selector (IN USE MIC), set the number of simultaneously-usable delegate units (TS-782).

5.1.1. Setting procedure

Note

When multiple Central units are connected, match all the settings of each unit. If settings differ among these Central units, only the setting of the unit with its Expansion switch set to MAIN takes effect.

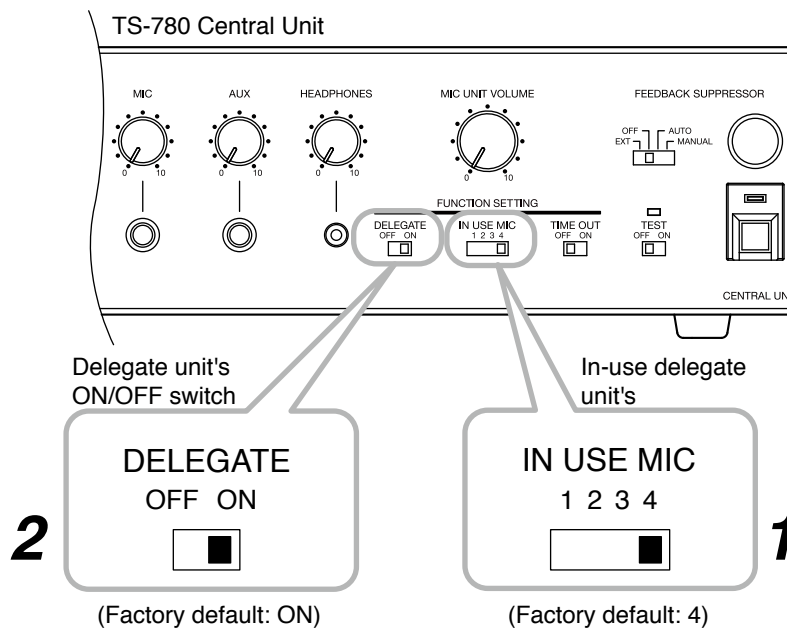

[When all delegate units are allowed to speak] (General conference style)

Step 1. Select the number of simultaneously-usable delegate units using the In-use delegate unit number selector.

Step 2. Set the Delegate unit ON/OFF switch to the ON position.

[When no delegate units are allowed to speak] (e.g. at the time of Voting)

Set the Delegate unit ON/OFF switch to the OFF position.

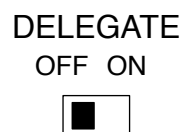

5.1.2. Conference unit operation

[Chairman unit]

Chairman units can speak at any time regardless of the setting of the Delegate Unit Restriction function.

[Delegate unit]

Up to the set number of Delegate units can speak simultaneously.

When the full set number of Delegate units are in use (their microphones have been turned on), no microphones of other Delegate units can be turned on, even if their Talk keys are pressed.

5.2. Automatic Mic-Off Function

The automatic mic-off function automatically turns off the in-use microphone when a break in speech exceeds 30 seconds.

By using this function, the Delegate unit's microphone turns off after 30-second break even if a speaker forgets to turn it off after use.

[Setting]

Set the Automatic mic-off setting switch to the ON (30 seconds of time out) position.

Tip

Set this switch to OFF if this function is unnecessary.

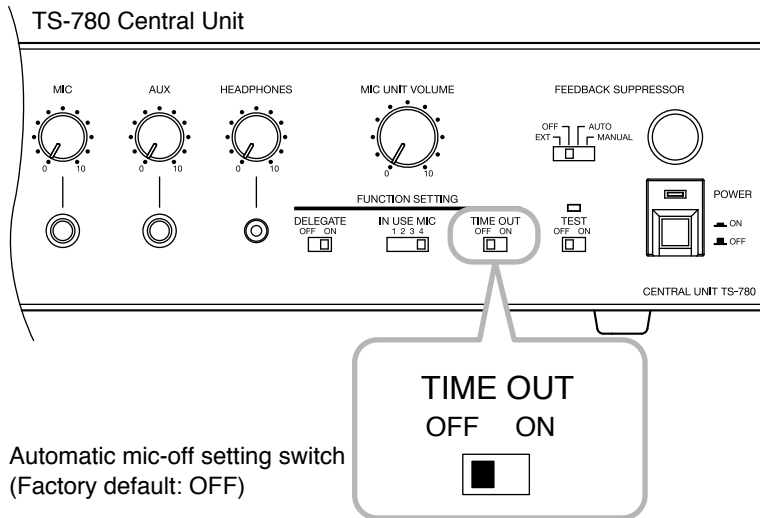

Notes

- For conferences in which long breaks in speech are expected, set the automatic mic-off setting switch to the OFF position.
- In areas with high levels of background noise, the Central unit may mistake the noise to be speech and the automatic mic-off function will not operate correctly. In such cases, this function should be disabled by placing the switch in the OFF position.
- In the system employing 2 or 3 Central units, it is not possible to operate the units with each different setting. Perform the same setting for all connected Central units.

5.3. Test Function

The test function is especially useful to check operation of all connected conference units.

This function allows the microphones of all connected conference units to turn on. In this event, no sound is output from their internal speakers, but audio signals are output from their Recording/Headphones output terminal.

All conference units can speak without operating the Talk key regardless of the Delegate unit ON/OFF switch setting.

[Setting]

Set the Test switch to the ON position.

Tip

After test completion, be sure to set this switch to OFF.

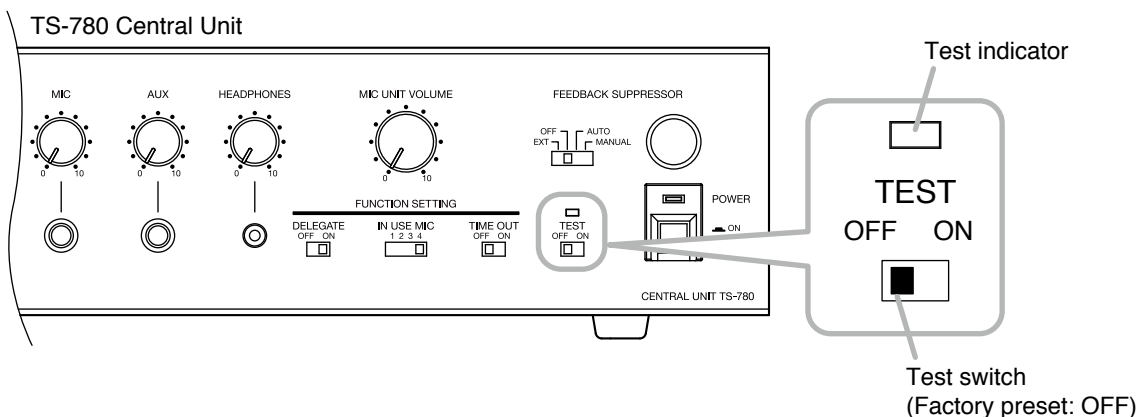

5.4. FBS (Feedback Suppressor) Function

An annoying screeching sound may be produced when using a public address system. It is referred to as "Acoustic feedback*" that will occur at various frequencies depending on the surrounding environment. The unit's built-in Feedback suppressor (FBS) function effectively suppresses acoustic feedback through simple operation (depresses the volume level at the feedback frequency). If the built-in FBS function cannot deal with the acoustic feedback, an external graphic equalizer (prepare separately) can be used for more effective feedback suppression.

* It will occur when a feedback loop is formed in the process that sound from a speaker is picked up by a microphone, re-amplified, and output through the speaker.

5.4.1. Using the built-in FBS function

Normally set the FBS function to the automatic operation mode (AUTO mode).

Note

If acoustic feedback cannot be suppressed with the built-in FBS function, widen the distance between the Chairman unit and Delegate units, reduce the output volume, or use an external graphic equalizer. (See p. 13 "Using an external graphic equalizer.")

5.4.1.1. Using in automatic operation mode (AUTO mode)

Set the Feedback suppressor switch to the AUTO position.

The FBS function automatically searches frequency that will cause acoustic feedback and suppresses the feedback by decreasing the volume level at such frequency.



5.4.1.2. Using in manual operation mode (MANUAL mode)

If acoustic feedback does not stop even using the FBS function in automatic operation mode, follow the procedure below to search the frequency that caused feedback, then suppress the feedback.

Step 1. Set the Feedback suppressor switch to the MANUAL position.

Step 2. While gradually rotating the Feedback suppressor control knob counterclockwise until it stops, seek the feedback point.

If acoustic feedback point is found, stop rotating the knob and do not touch it any more.

Note

Do not apply excessive force to the knob when it comes to a stop, as doing so may cause damage to the knob.

Step 3. If acoustic feedback does not stop even when the knob reaches the immovable position, seek the feedback point by gradually rotating the Feedback suppressor manual control knob clockwise to its stop.

If acoustic feedback point is found, stop rotating the Knob and do not touch it any more.

Note

When feedback occurs again, repeat Steps 2 and 3 to find the feedback point once again.



Rotate counterclockwise.

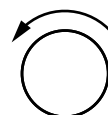

Rotate clockwise.



5.4.2. Using an external graphic equalizer

Step 1. Connect an external equalizer to the unit as shown below.

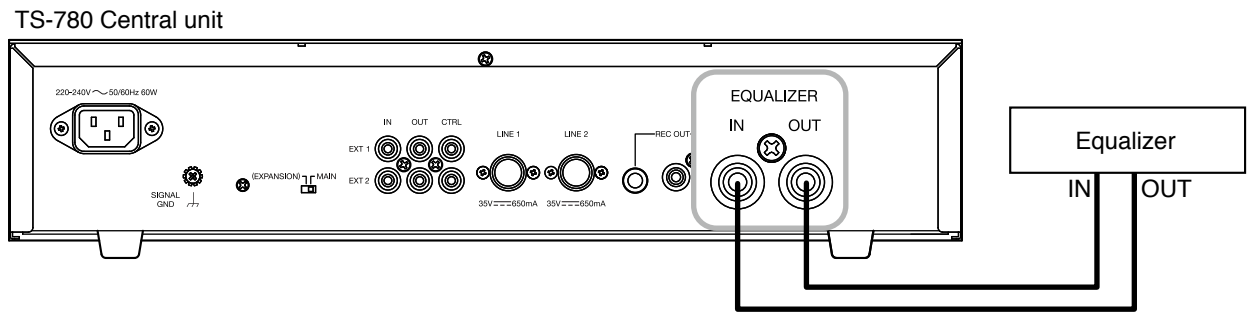

Step 2. Set the Feedback suppressor switch to the EXT position.



Step 3. Take measures against acoustic feedback using the graphic equalizer.

For operation method of the graphic equalizer, read the instruction manual supplied with it.

6. OPERATING CHAIRMAN AND DELEGATE UNITS

This section explains how to operate Conference units in a conference.
Be sure to set the TEST switch of the TS-780 Central Unit to OFF before use. (See p. 11.)

6.1. Making Speech

Step 1. Press the TALK key once.

The microphone in-use indicator lights, and the microphone turns on.

Notes

- No sound is output from the internal speaker of the operated unit while the Microphone in-use indicator remains lit. However, audio signal is output from the Recording/Headphone output terminal.
- While the Chairman unit is in priority speech mode (see p. 15), other unit's microphones do not turn on even if their Talk keys are pressed.
- The microphones of some Delegate units may not turn on even if their Talk keys are pressed, depending on the setting of the Delegate Unit Restriction Function (see p. 10).

Step 2. Speak into the microphone.

Step 3. Press the Talk key again after speech completion.

The Microphone in-use indicator extinguishes and sound is audible from the operated unit's speaker.

[Example: TS-782 Delegate unit]

Microphone in-use indicator: Lights.

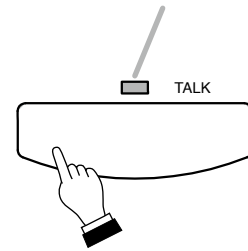

Microphone in-use indicator: Extinguishes.

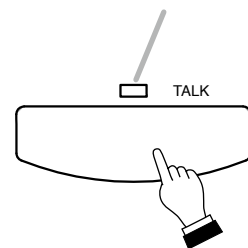

6.2. Making Priority Speech (Chairman Unit TS-781 Only)

Holding down the priority key on the Chairman unit gives that unit speech priority and allows it to interrupt other conference units.

Step 1. Press the Priority key.

The microphone in-use indicator lights, and the microphone turns on. At the same time, a single tone chime sounds at the remaining conference units.

Note

No sound is output from the internal speaker of the operated unit while the Microphone in-use indicator remains lit. However, audio signal is output from the Recording/Headphone output terminal.

Microphone in-use indicator: Lights.

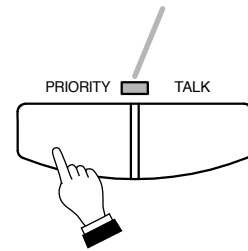

Step 2. Speak while holding down the Priority key.

No delegate units can be used while the Priority key is pressed.

If 2 or more chairman units exist, when other chairman unit's priority key is pressed during priority speech, this latest key-operated unit takes precedence over other conference units.



Step 3. The microphone in-use indicator goes off, turning on the built-in speaker.

Note

Any previous speech that has been interrupted by the priority speech is not restored even after priority speech completion. Press the Talk key again, and make a speech after microphone in-use indicator lights.



Note

In the system employing 2 or 3 chairman units, even while 1 unit is making priority speech, other chairman unit(s) can also make priority speech by pressing the Priority key although a single-tone chime is not sounded.

7. RECORDING

In this system, the conference contents can be recorded and played back using the Central unit's internal MP3 recorder in MP3 format. It is also possible to perform recording using an external recording equipment.

7.1. Using the TS-780 Central Unit's Built-in MP3 Recorder

The conference contents can be recorded to and played back from the SD/SDHC card ("SD card" herein) in MP3 format using the TS-780 Central unit's built-in MP3 recorder.

7.1.1. Nomenclature and Functions of the MP3 Recorder

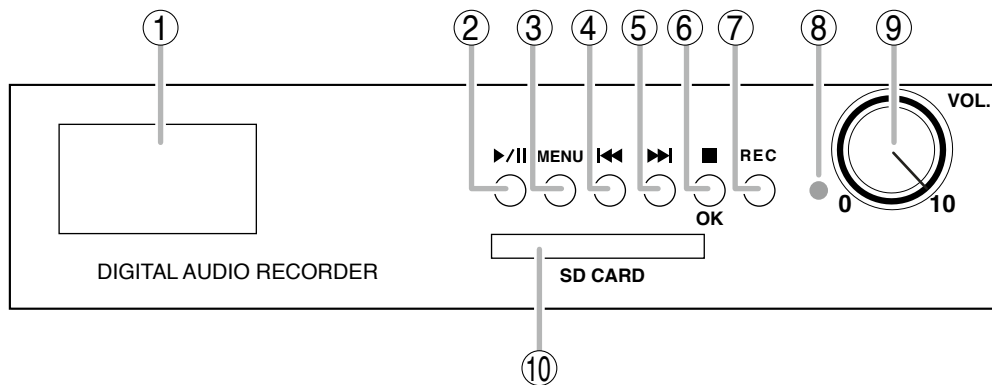

Note

Be sure to press each button one by one. Simultaneously pressing two or more buttons may cause equipment malfunction.

1. Display section

Displays such information as operation status, selected sound source file name, and elapsed time.

2. Playback/Pause button [▶/II]

Calls up the last played sound source file when pressed, placing the recorder in pause state. When pressed again, playback resumes.

The recorder is placed in pause state when this button is pressed during playback. Besides, when pressed in pause state, playback starts from the pause position.

Note

The sound source file is not called up immediately after power-on or SD card insertion even if this button is pressed. Select the sound source file from the Main Menu to play back.

3. Menu button [MENU]

Displays the Main Menu when pressed.

4. Backward button [◀◀]

Used to select the MENU.

The display moves to the previously selected item when this button is pressed.

When pressed during playback, the recorder moves to the beginning of the previously selected sound source file.

Holding down this button during playback decreases the sound volume. Volume level set here is the maximum volume adjustable with the Volume control knob (9).

Note

If the volume has been set to "0" with this button, audio signals are not output even when the volume is increased with Volume control knob (9).

5. Forward button [▶▶]

Used to select the MENU.

The display moves to the next selection item when this button is pressed.

The recorder skips to the beginning of the next sound source file when pressed during playback. If skips to the beginning of the first sound source file when pressed during the last track playback. Holding down this button during playback increases the sound volume. Volume level set here is the maximum volume adjustable with the Volume control knob (9).

6. Stop/OK button [■, OK]

Stops operation when pressed during recording.

Skips to the beginning of the sound source file being played back when pressed during playback, stopping the operation.

Confirms the setting contents when pressed during various settings.

7. Record button [REC]

Places the recorder in recording pause state when pressed once, and performs audio signal recording when pressed again.

Recording format is MP3 only. Set the bit rate from the menu. (See p. 22.)

8. Operation indicator

Flashes or lights as shown in the table below depending on the operation state. Remains unlit when the recorder is not operating.

Lit red	Recording in progress
Flashing red	Recording in pause
Lit green	Playback in progress
Flashing green	Playback in pause

9. Volume control knob

Adjusts the volume level. Turn the knob clockwise to increase the volume and counterclockwise to decrease it.

10. SD card slot [SD CARD]

Insert the SD card to be used. When inserting, push the SD Card in the direction as shown below until it locks into place.

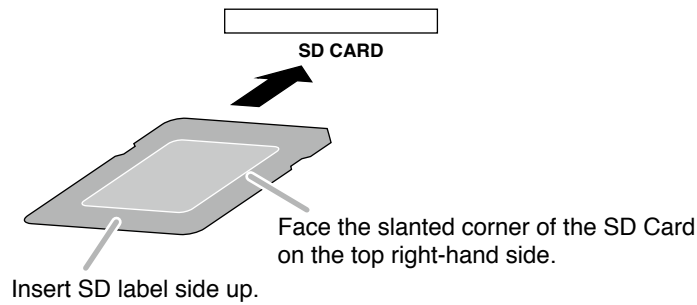

When removing the SD card, press on the center of the card and pull it straight out.

Note

Do not remove the SD card before turning off the power to protect data.

7.1.2. Before use

7.1.2.1. Handling precautions

- Be sure to make a backup copy of the sound source file recorded on the SD card to a PC. There is a possibility that data will be lost due to unit's breakdown or mishandling.
- When inserting or removing the SD card, do not apply excessive force to the card slot. Doing so may cause damage to the unit or a scratch on the SD card.
- The Recorder is a high-precision electronic device. When moving the unit, be sure to take out the SD card from the slot. Doing otherwise may cause damage to the unit or breakage to the sound source media.
- The backup battery is fully charged in 5 days when connected to AC mains. Once fully charged, the battery maintains the time setting for 4 months.

7.1.2.2. Usable SD card

- An SD card or SDHC card up to 32 GB can be used.
- The compatible file format is FAT16 and FAT32.
- A mini SD/SDHC card and micro SD/SDHC card cannot be used.



The SD and SDHC logos are registered trademarks of the SD Card Association.

Notes

- An SD card is not supplied with the unit. Prepare it separately.
- SD/SDHC card, even though satisfying the conditions above, may not be used with the unit depending on its characteristics and record conditions.

7.1.2.3. Menu

The Menu structure of the MP3 Recorder is as follows.

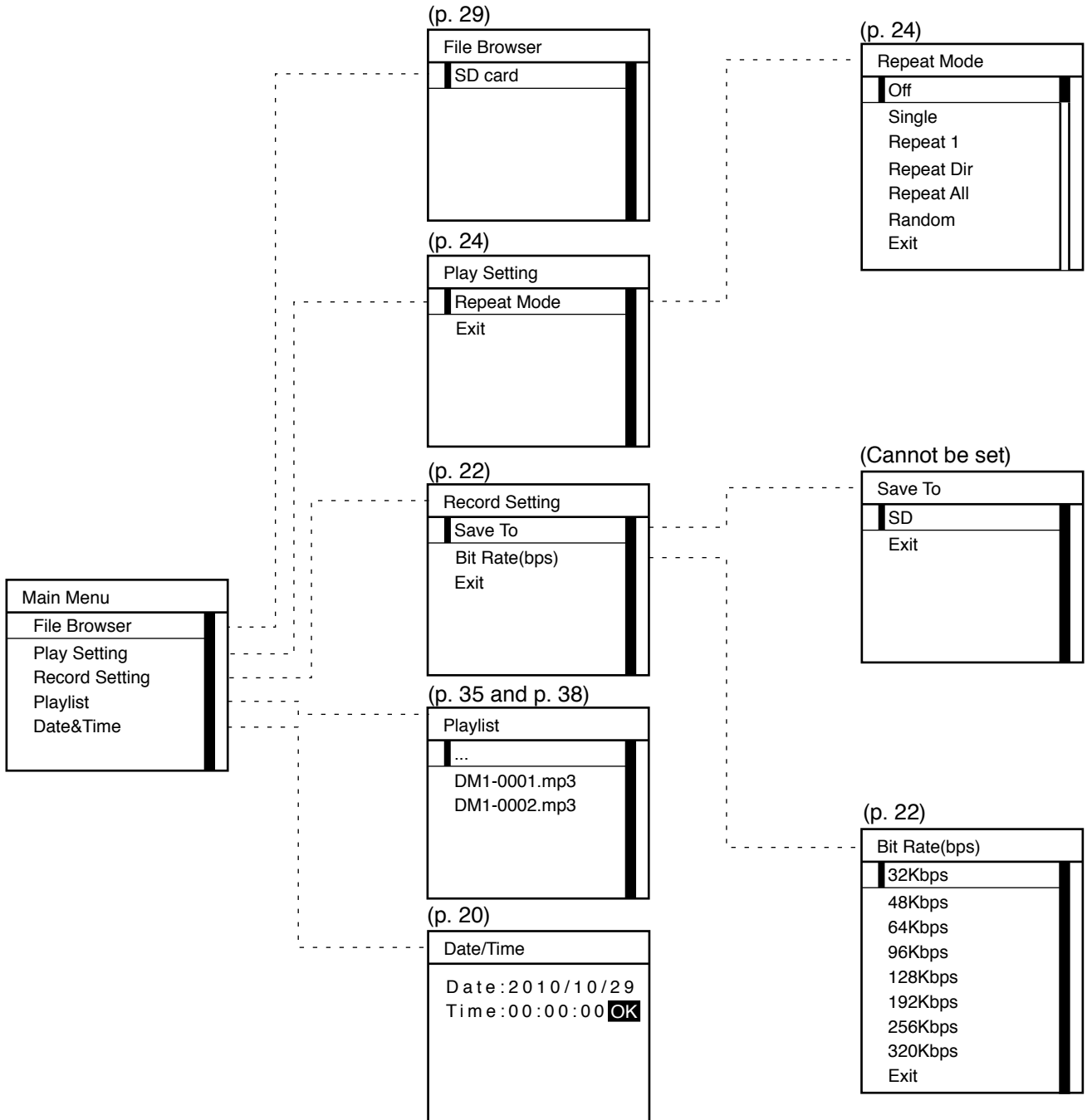

7.1.3. Settings

[Date and Time settings]

Set Date and Time.

Step 1. Press the Menu button on the MP3 reorder's front panel.
The Main Menu appears.

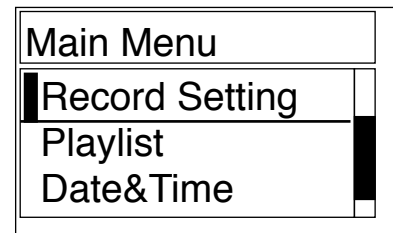

Step 2. Press the Backward button or Forward button to select "Date & Time" on the Main Menu.

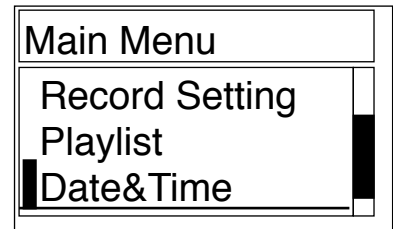
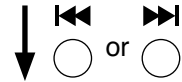

Step 3. Press the OK button.
The Date and Time setting screen appears.

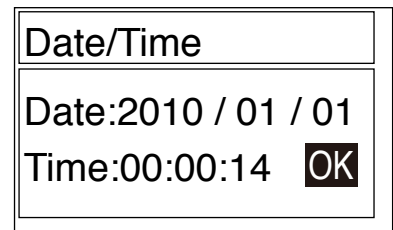

Step 4. Press the Forward button once.
Year is underlined.

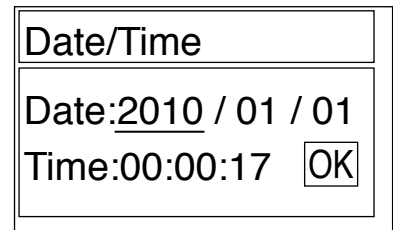

Step 5. Press the OK button.
The underline cursor flashes, placing in Year setting mode.



To the next page

Step 6. Press the Backward button or Forward button to select Year.
This figure increases as the Backward button is pressed.
It decreases as the Forward button is pressed.

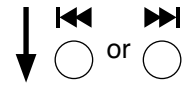
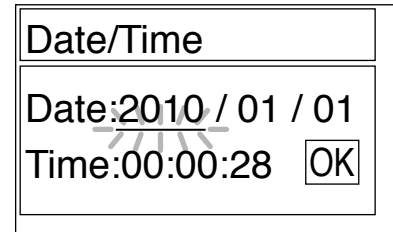

Step 7. Press the OK button.
The underline cursor stops flashing, and Year is set.

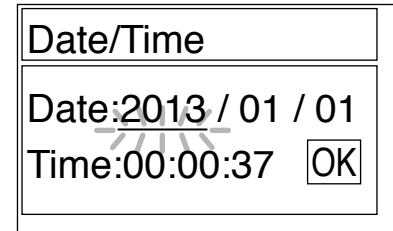

Step 8. Press the Forward button once.
The underline cursor moves to the figure indicating Month.

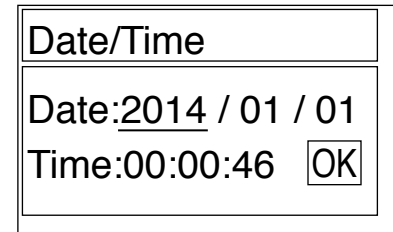

Step 9. Set Month in the same way as in Steps 5 to 7.

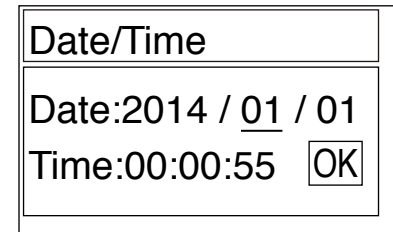

Step 10. Set Date, Hour, Minute, and Second in order in the same way as in Steps 4 to 8.

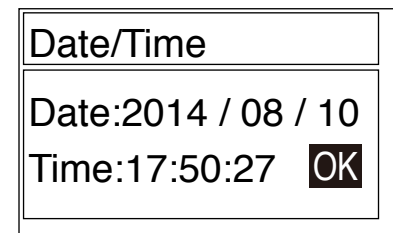

Step 11. After setting Second, press the Forward button once.
The "OK" is highlighted.

Step 12. Press the OK button.
Date and Time are confirmed, and the screen reverts to the Main Menu.

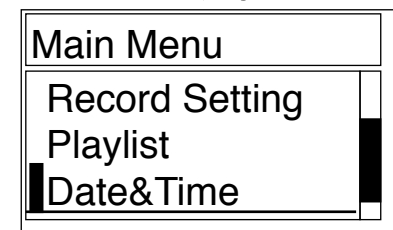

[Bit rate settings]

Set the bit rate at the time of recording depending on the required sound quality.

Tip

Recording format is MP3 only.

Step 1. Press the Menu button on the MP3 reorder's front panel.
The Main Menu appears.

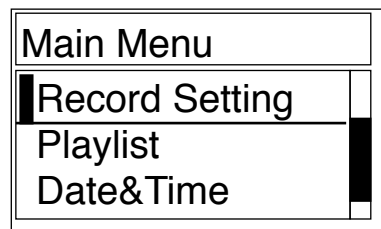

Step 2. Press the Backward button or Forward button to select "Record Setting" in the Main Menu.

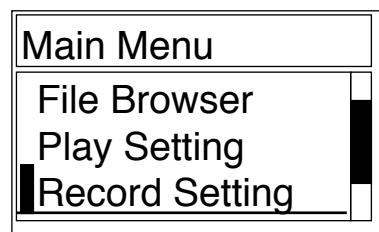
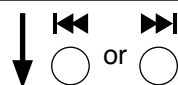

Step 3. Press the OK button.
The Record Setting screen appears.

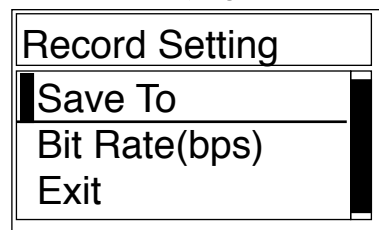

Step 4. Press the Backward button or Forward button to select "Bit Rate (bps)."

Note: "Save To" item cannot be set.

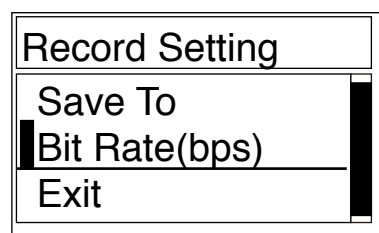

Step 5. Press the OK button.
The Bit Rate (bps) setting screen appears.



To the next page

Step 6. Press the Backward button or Forward button to select the bit rate to be set.

The settable bit rates are as follows.

- 32 Kbps
- 48 Kbps
- 64 Kbps
- 96 Kbps
- 128 Kbps
- 192 Kbps
- 256 Kbps
- 320 Kbps

Tip

Default setting is 128 Kbps.

Step 7. Press the OK button.

The set content is displayed for about 2 seconds and then confirmed.

The screen reverts to the Record Setting screen.

Step 8. Press the Menu button.

The screen reverts to the Main Menu.

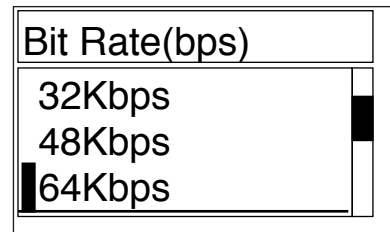
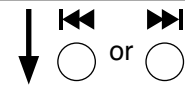
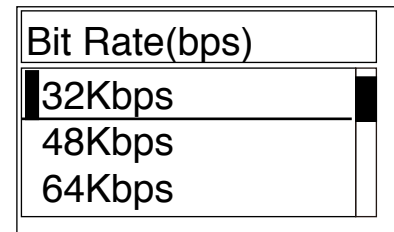

(When 64 Kbps is selected)

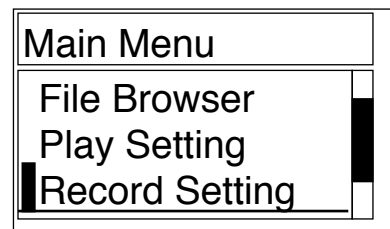
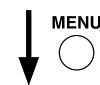
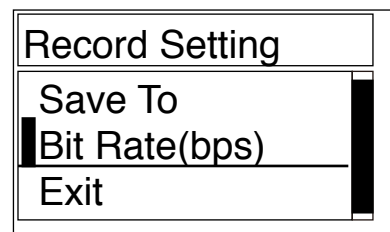
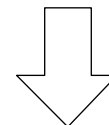
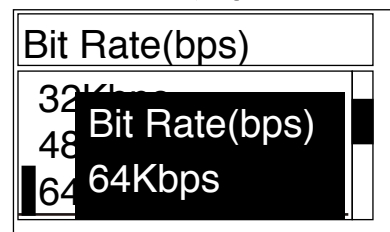

[Repeat mode settings]

Set the repeat mode (Repeating operation) at playback.

Step 1. Press the Menu button on the MP3 reorder's front panel.
The Main Menu appears.

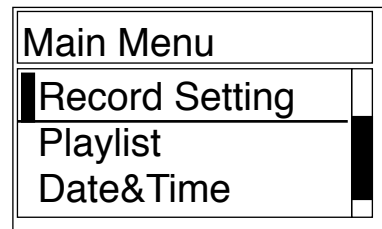

Step 2. Press the Backward button or Forward button to select "Play Setting" in the Main Menu.

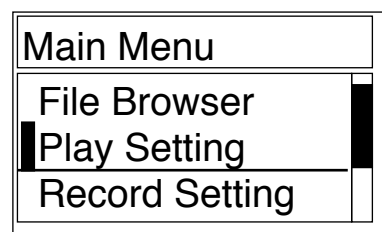

Step 3. Press the OK button.
The Play Setting screen appears.

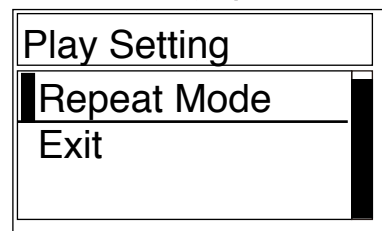

Step 4. Press the Backward button or Forward button to select "Repeat Mode," then press the OK button.
The Repeat Mode setting screen appears.

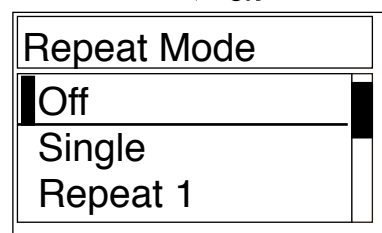







Tip

When wishing to cancel the setting, select "Exit," then press the OK button.

Step 5. Press the Backward button or Forward button to select the Repeat Mode to be set.
The settable Repeat modes are following 6 modes.
Shown below is each operation.



To the next page

- Off  : Does not perform repeat.
- Single  : Plays back only the selected sound source file once, then stops.
- Repeat 1  : Repeatedly plays back only the selected sound source file.
- Repeat Dir  : Repeatedly plays back the sound source files contained in the folder including the selected sound source file. This mode is not used normally.
- Repeat All  : Repeatedly plays back all sound source files contained on the SD card.
- Random  : Repeatedly plays back all sound source files contained on the SD card in random order.

Step 6. Press the OK button.
The set contents are displayed for about 2 seconds and then confirmed.

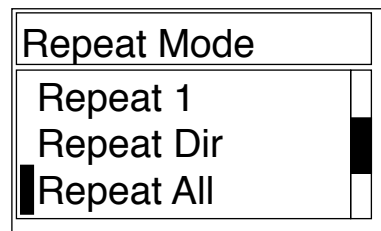

(When Repeat All is selected)

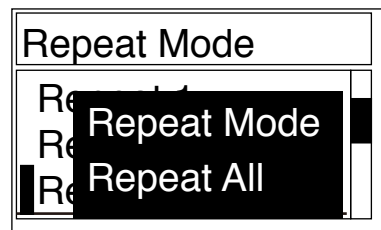

Step 7. Press the Menu button.
The screen reverts to the Main Menu.

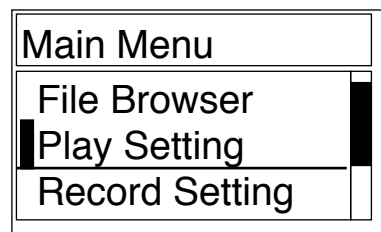

7.1.4. Recording

Note

Never switch off the unit nor remove the SD card during recording. The Recording file is lost.

[Record screen]

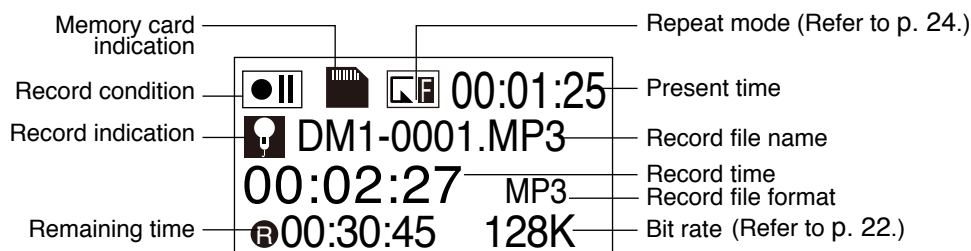

Step 1. Insert the SD card into the SD card slot.

[E0] indication is displayed for several seconds, followed by "Memory Card Check" indication, checking whether the SD card is compatible to the recorder or not. When the indication disappears, the SD card is ready for use.

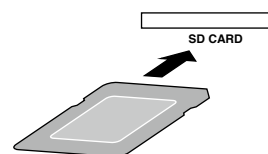

Note

If the inserted SD card is not compatible, [E0] indication remains displayed. In this case, initialize the SD card in FAT16 or FAT32 format on a PC running the Windows operating system or use the new SD card.

Step 2. Press the Record button.

The Recording screen appears, and the recorder is placed in standby mode. The operation indicator flashes red.

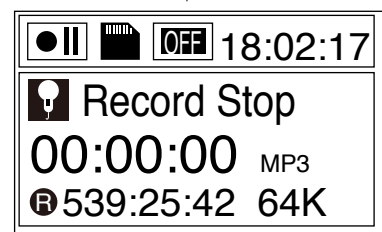
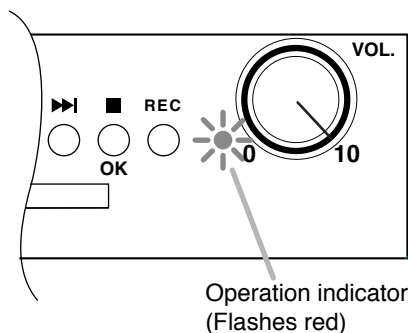

To the next page

Step 3. Press the Record button again.

A file name to be recorded is displayed, and recording begins. The operation indicator lights red.

Tip

A file name is automatically created. A serial number starting with 0001 is assigned to a file name in numerical order skipping used numbers.

File name: DM1-0001.mp3

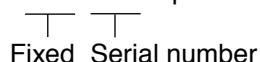

Note

Do not perform any operations other than a press of the pause or stop button during recording, as doing so may cause malfunction.

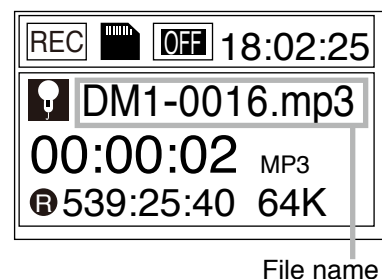
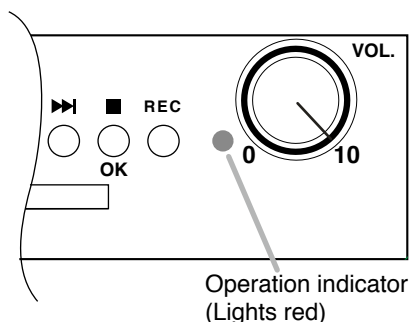

File name

Step 4. To temporarily stop recording, press the Record button again.
The screen changes in standby state.
The operation indicator flashes red.

Tip

To restart recording, press the Record button again.

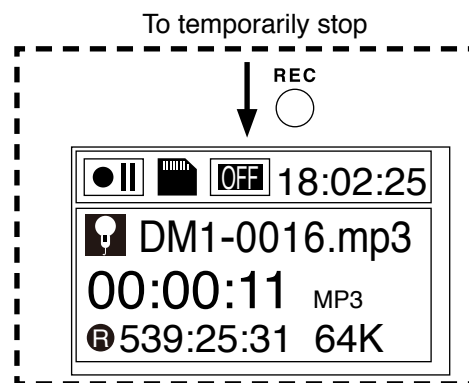

Step 5. To stop recording, press the Stop button.
Recording is stopped, and the operation indicator goes off.

Tip

To resume recording, press the Record button and recording starts instantly.

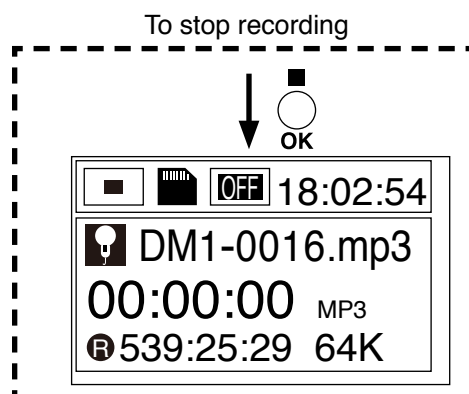

Note

Up to 500 files can be displayed in the sound source file list when in playback mode.
(See p. 29 "Playback.")

Sound source files created beyond 500 files cannot be played back as they are not displayed in the unit. In this case, delete unnecessary sound source files to keep the number of files 500 or less on the SD card, or play back the hidden files using a PC.

Tips

- The recorded sound source file is saved in the DMIREC folder on the SD card. This folder is created automatically. Do not change this folder name.
- A file name should be within 64 characters long including the extension when changing it on a PC.
- The maximum recording time per recording file is the time required to record a file corresponding to 2 GB of file size.

(Example)

For bit rate of 128 Kbps: About 35 hours and 36 minutes

For bit rate of 64 Kbps: About 71 hours and 12 minutes

For an SD card of 2 GB or less, the maximum recording time is the maximum time to be able to make recording on the card.

- The table on the next page shows the recording time on a SD card depending on memory card size and bit rate.

[Recording time on an SD card depending on memory card size and bit rate]

Bit rate	SD card size				
	1 GB	2 GB	4 GB	8 GB	16 GB
32 Kbps	70 h 50 min	142 h 25 min	275 h 8 min	552 h 31 min	1105 h 3 min
48 Kbps	47 h 13 min	94 h 56 min	183 h 25 min	368 h 21 min	736 h 42 min
64 Kbps	35 h 25 min	71 h 12 min	137 h 34 min	276 h 15 min	552 h 31 min
96 Kbps	23 h 36 min	47 h 28 min	91 h 42 min	184 h 10 min	368 h 21 min
128 Kbps	17 h 42 min	35 h 36 min	68 h 47 min	138 h 7 min	276 h 15 min
192 Kbps	11 h 48 min	23 h 44 min	45 h 51 min	92 h 5 min	184 h 10 min
256 Kbps	8 h 51 min	17 h 48 min	34 h 23 min	69 h 3 min	138 h 7 min
320 Kbps	7 h 5 min	14 h 14 min	27 h 30 min	55 h 15 min	110 h 30 min

7.1.5. Playback

[Play screen]

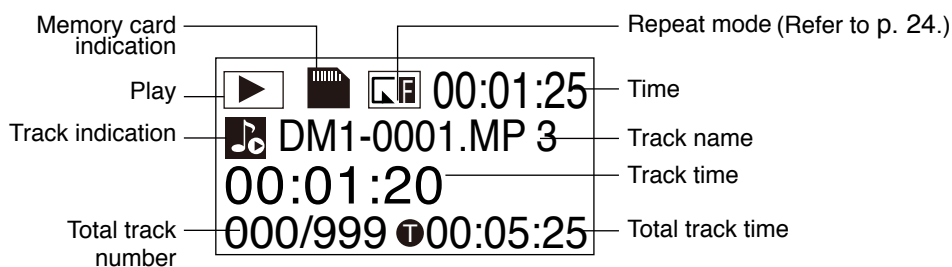

Note

When using the sound source file recorded by other recording equipment than the built-in recorder, the lengths of the folder name and file name are limited to the number of characters specified below.

Folder name: Up to 64 alphanumeric characters long

File name: Up to 64 alphanumeric characters long (including the extension)

Step 1. Insert the recorded SD card into the SD card slot.
The Main Menu appears.

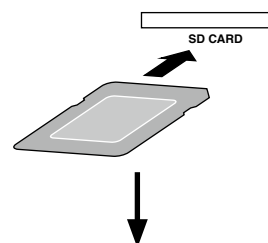

Step 2. Press the Backward button or Forward button to select "File Browser" in the Main Menu.

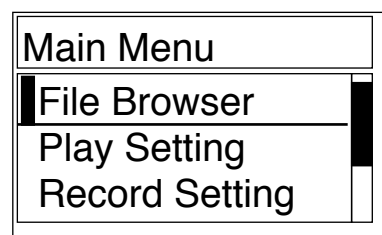

Step 3. Press the OK button.
The File browser screen appears, and the SD card indication is displayed in the menu.

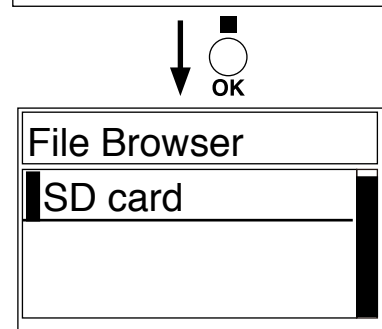

Step 4. Press the OK button.
A sound source file save folder (DM1REC) appears.

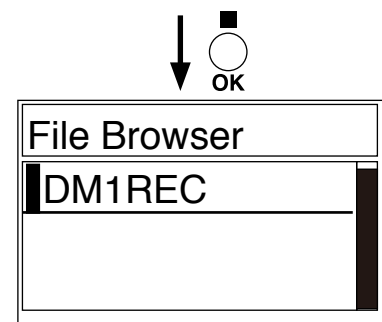

Step 5. Press the OK button.
A Sound source file list in the File Browser appears.



Note

Number of the displayable sound source files is up to 500 files.

To the next page

Step 6. Press the Backward button or Forward button to select the sound source file to be played back.

Tip

Holding down the Backward button or Forward button scrolls display of files in the sound source file list fast backward or forward.

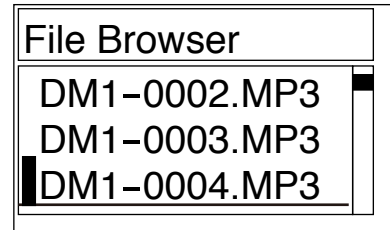
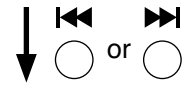
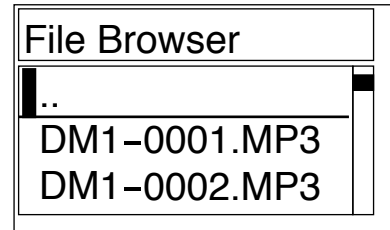

(When the DM1-004.MP3 is selected)

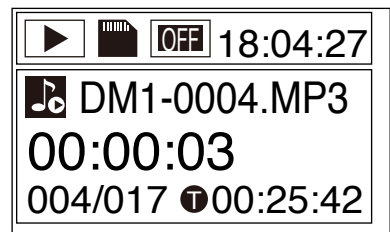
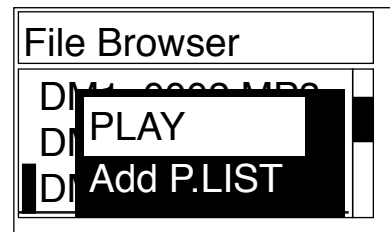

Step 7. Press the OK button.
The operation selection menu appears.

Note

Do not remove the SD card to protect data.

Step 8. Press the Backward button or Forward button to select "PLAY," then press the OK button.
The operation indicator lights green and the selected sound source file is played back according to the set Repeat mode.

Note

Do not perform other operations than volume adjustment, sound source forward/backward, pause, or stop during playback, as doing so may cause equipment malfunction.

Step 9. Adjust the volume level with the volume control knob.
Turn the knob clockwise to increase the volume and counterclockwise to decrease it.

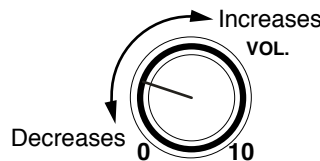

Step 10. To temporarily stop playback, press the Playback/Pause button.
The operation indicator flashes green, and the screen changes in standby state.

Tip

To restart playback, press the Playback/Pause button again.

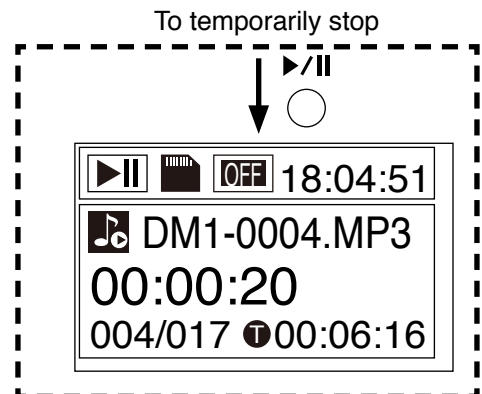

To the next page

Step 11. To skip to the next sound source file during playback, press the Forward button.
The recorder skips to the beginning of the next sound source file in the sound source file list and continues to play back.

Tip

Holding down the Forward button displays the volume level in numerical value and increases it.
Adjustable range is from 0 (minimum) to 74 (maximum).
Default value is 74.
Volume level set here is the maximum volume adjustable with the Volume control knob.

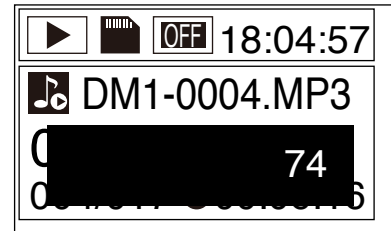
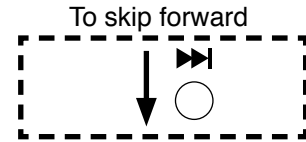

Step 12. To skip to the previous sound source file during playback, press the Backward button.
The recorder skips to the beginning of the previous sound source file in the sound source file list, and continues to play back.

Note

Holding down the Backward button displays the volume level in numerical value and decreases it.
Adjustable range is from 0 (minimum) to 74 (maximum).
Default value is 74.
Volume level set here is the maximum volume adjustable with the Volume control knob. Therefore, if the volume has been set to "0" through this operation, audio signals are not output even if the Volume control knob is turned fully clockwise.

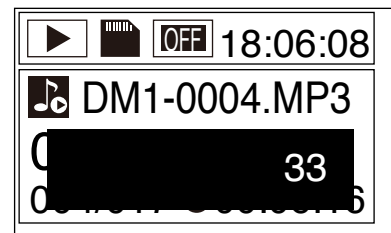
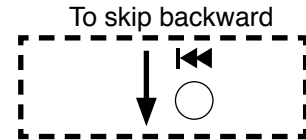

Step 13. To stop playback, press the Stop button.
The recorder returns to the beginning of the sound source file being played back and changes in stop state.
The operation indicator goes off.

Tip

To resume the sound source file playback at the stop position, press the Playback/Pause button. However, when the power is cycled or the SD card is inserted or removed after playback was stopped, perform operation again from Step 2.

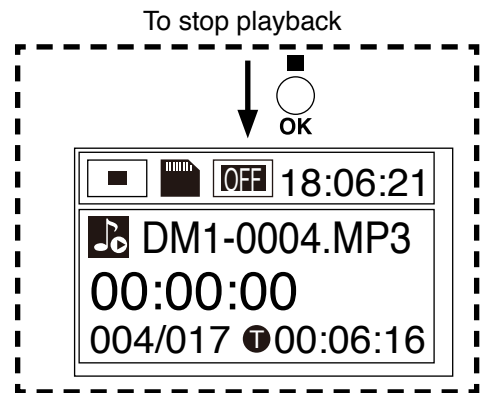

Step 14. When the playback is finished, press the Menu button.
The screen reverts to the Main Menu.

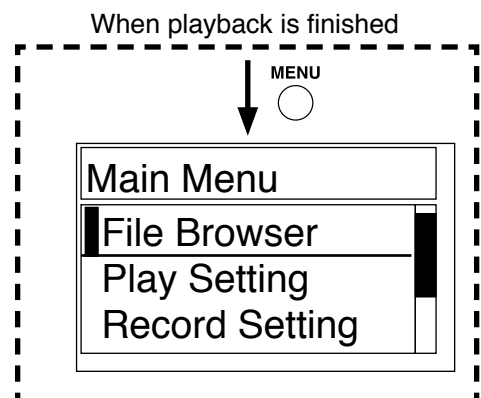

7.1.6. Deleting a file

Delete unnecessary sound source files from the SD card.

Note

A read-only file cannot be deleted. To delete it, you first need to cancel the read-only setting.

Tip

Files can also be deleted using a PC.

Step 1. Select the sound source file to be deleted following the same procedures as in Steps 1 to 6 of "Playback" (see p. 29).

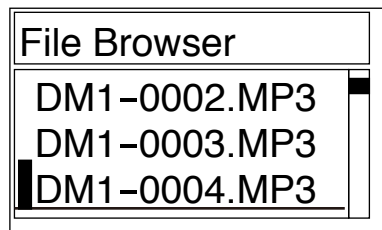

(When the DM1-004.MP3 is selected)

Step 2. Press the OK button.
The operation selection menu (File Browser) appears.



Note

Do not remove the SD card to protect data.

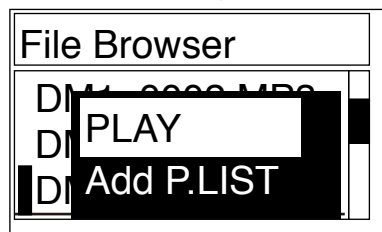

Step 3. Press the Backward button or Forward button to select "DELETE."



Step 4. Press the OK button.
The Deletion confirmation screen appears.

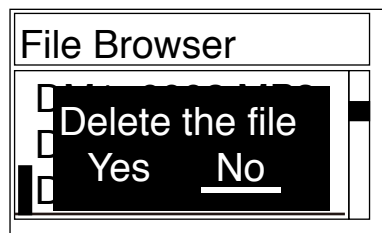

Step 5. Press the Backward button or Forward button once.
The underline cursor moves from "No" to "Yes" in the Deletion confirmation screen.

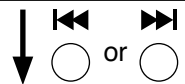

Tip

To cancel deletion, select "No," then press the OK button.

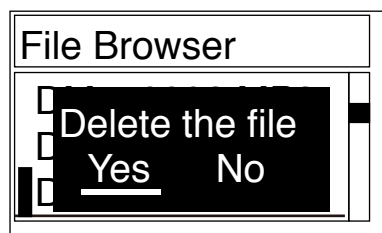

Step 6. Press the OK button.
The selected sound source file is deleted and the screen reverts to the Play list screen.



To the next page

Step 7. To delete the next sound source file if there is, press the Backward button or Forward button to select the file to be deleted, then perform Steps 1 to 6.

Step 8. Press the Menu button.
The screen reverts to the Main Menu.

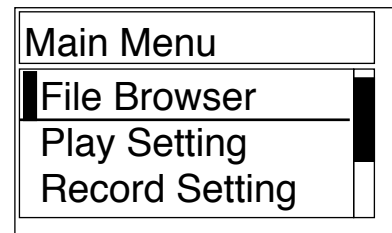
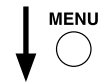
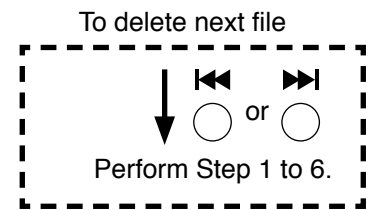
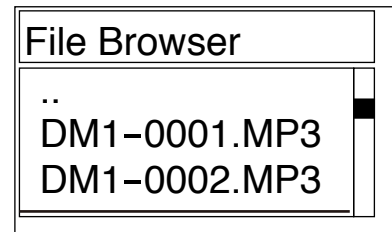

7.1.7. Using the Play list

You can use the Play list for playback.

When the sound source files used often are programmed in the Play list, only such programmed files can be played back in order.

Note

To ensure correct operation of equipment, the number of the files to be registered in the Play list is limited to 80. Registering more than 80 files may cause equipment malfunction.

[Registering to the Play list]

Step 1 Select the sound source file to be registered following the same procedures as in Steps 1 to 6 of "Playback" (see p. 29).

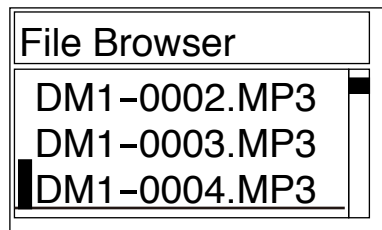

(When the DM1-004.MP3 is selected)

Step 2. Press the OK button.
The operation selection menu is displayed.



Note
Do not remove the SD card to protect data.

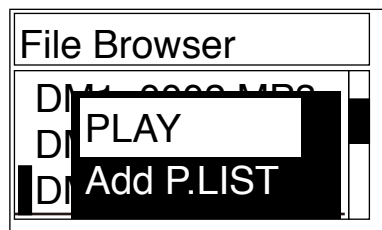

Step 3. Press the Backward button or Forward button to select "Add P. LIST."

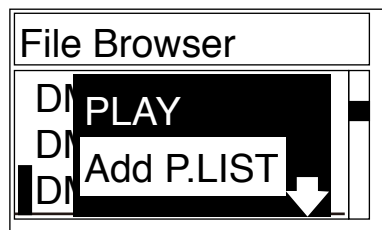

Step 4. Press the OK button.
The selected sound source file is registered in the Play list.



Step 5. To register the next sound source file if there is, repeat Steps 1 to 4.

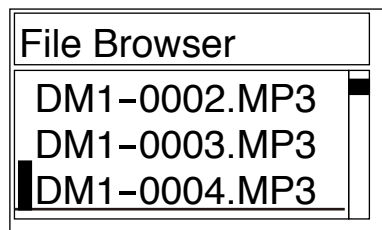

Step 6. When your desired sound source files are all registered, press the Menu button.
The screen reverts to the Main Menu.

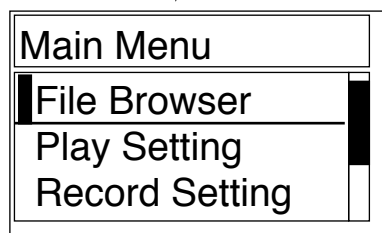

Note

The registered play list content is saved into the unit's internal memory, but not in the SD card. After completion of the Play list registration, reverting the screen to the operation selection menu with the SD card removed or other SD card inserted causes the registered Play list content to be lost.

[Playing back files in the Play list]

The sound source files registered in the Play list are played back in the sequential order of registration.

Step 1. Insert the SD card having been recorded and registered in the Play list into the SD card slot.

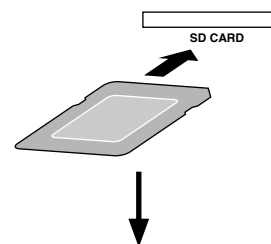

Step 2. Press the Backward button or Forward button to select "Playlist" in the Main Menu.

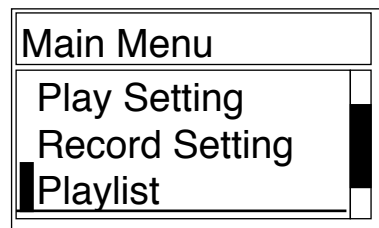

Step 3. Press the OK button. The Play list screen appears.

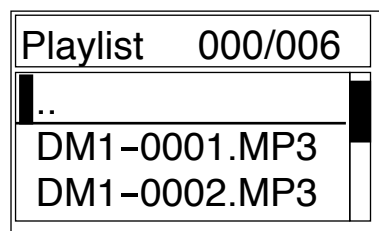

Step 4. Press the Backward button or Forward button to select the sound source file to be played back.

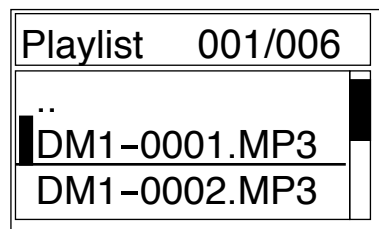

Step 5. Press the OK button. The operation selection menu appears.

(When the DM1-0001.MP3 is selected)



Note

Do not remove the SD card to protect data.

Step 6. Press the Backward button or Forward button to select "PLAY," then press the OK button. The operation indicator lights green, the selected sound source file is played back, and the subsequent files in the Play list is to be played back in order.

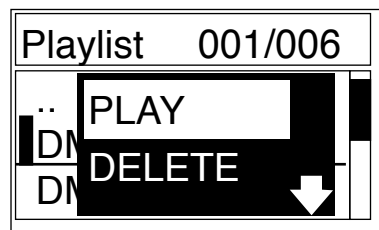

To the next page

Note

Do not perform other operations than volume adjustment, sound source forward/backward, pause, or stop during playback, as doing so may cause equipment malfunction.

Tip

To stop playback, select "Exit," then press the OK button.

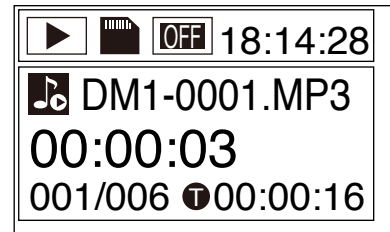
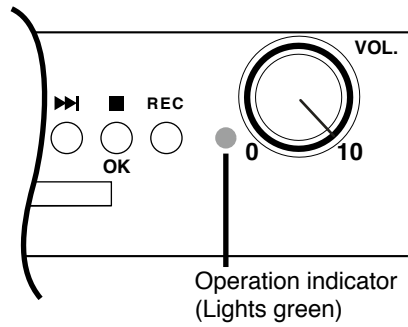

Step 7. Adjust the volume level with the Volume control knob.
Turn the knob clockwise to increase the volume and counterclockwise to decrease it.

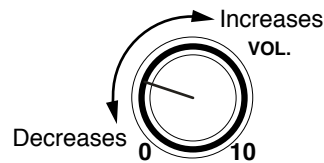

Step 8. To temporarily stop playback, press the Playback/Pause button.
The screen changes in standby state.
The operation indicator flashes green.

Tip

To restart playback, press the Playback/Pause button again.

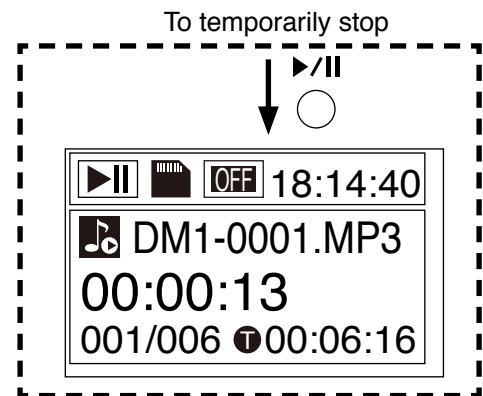

Step 9. To skip to the next sound source file during playback, press the Forward button.
The recorder skips to the beginning of the next sound source file in the Play list, and continues to play back.

Tip

Holding down the Forward button displays the volume level in numerical value and increases it.
Adjustable range is from 0 (minimum) to 74 (maximum).
Default value is 74.

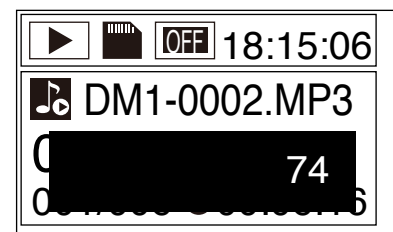
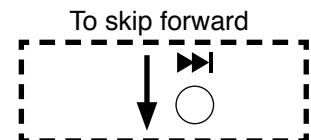

Step 10. To skip to the previous sound source file during playback, press the Backward button.
The recorder skips to the beginning of the previous sound source file in the Play list, and continues to play back.

Note

Holding down the Backward button displays the volume in numerical value and decreases it.
Adjustable range is from 0 (minimum) to 74 (maximum).
Default value is 74.
Volume level set here is the maximum volume adjustable with the Volume control knob. Therefore, if the volume has been set to "0" with this adjustment, audio signals are not output even if the Volume control knob is turned fully clockwise.

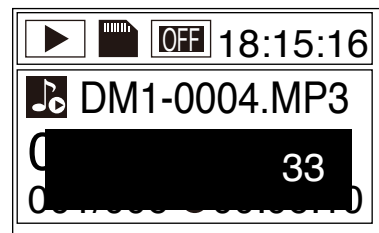
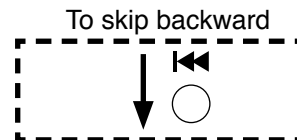

Step 11. To stop playback, press the OK button.
The recorder returns to the beginning of the sound source file being played back and changes in stop state.
The operation indicator goes off.

Tip

To resume the sound source file playback at the stop position, press the Playback/Pause button.
However, when the power is cycled or the SD card is inserted or removed after playback was stopped, perform operation again from Step 1.

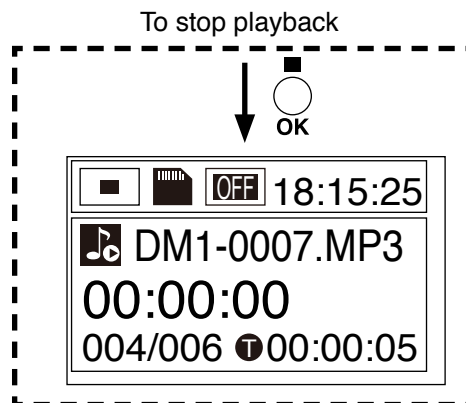

Step 12. When the playback is finished, press the Menu button.
The screen reverts to the Main Menu.

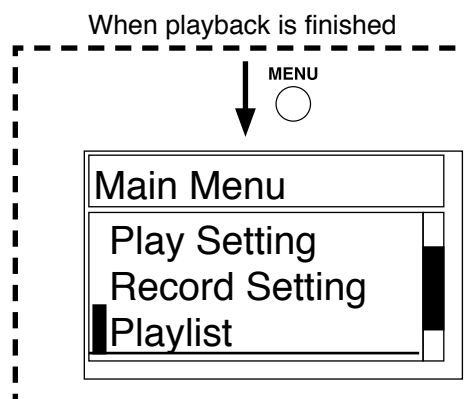

[Deleting a file from the Play list]

The sound source file no longer needed to be registered in the Play list can be deleted from the Play list.

Note

The sound source file itself will not be deleted from the SD card even if it has been deleted from the Play list. To delete unnecessary sound source files from the SD card, read "Deleting a file" (see p. 32).

Tip

If you delete the sound source file from the SD card, the file itself is also automatically deleted from the Play list.

Step 1. Select the sound source file to be deleted from the Play list following the same procedures as in Steps 1 to 3 of "Playing back files in the Play list" (see p. 35).

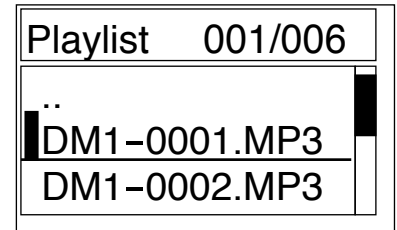

(When the DM1-001.MP3 is selected)

Step 2. Press the OK button.
The operation selection menu appears.



Note
Do not remove the SD card to protect data.

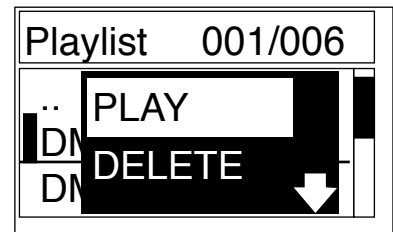

Step 3. Press the Backward button or Forward button to select "DELETE."

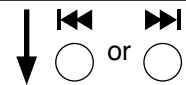

Step 4. Press the OK button.
The Deletion confirmation screen appears.

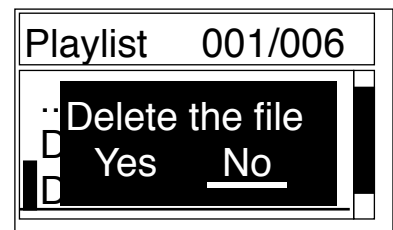

Step 5. Press the Backward button or Forward button once.
The underline cursor moves from "No" to "Yes" in the Deletion confirmation screen.

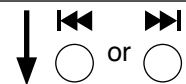

To the next page

Tip

To cancel deletion, select "No," then press the OK button.

Step 6. Press the OK button.
The selected sound source file is deleted from the Play list, and the screen reverts to the Playlist screen.

Step 7. To delete the next sound source file if there is, repeat Steps 1 to 6.

Step 8. When your desired sound source files are deleted, press the Menu button.
The screen reverts to the Main Menu.

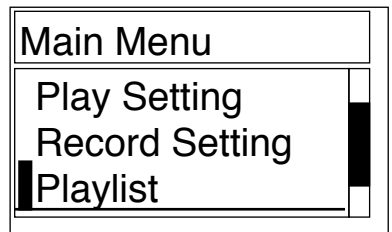
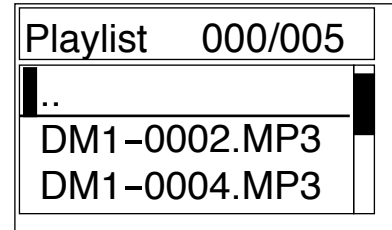
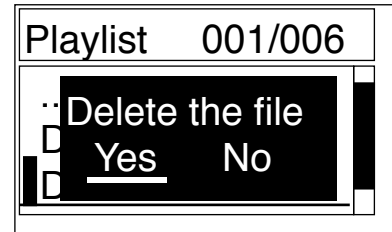

7.2. Using an External Recording Equipment

The contents of the conference can be recorded by connecting recording equipment to the TS-780 Central Unit, TS-781 Chairman Unit, or TS-782 Delegate Unit.

7.2.1. Recording with the Central Unit

Step 1. Connect the recording output on the rear panel of the TS-780 Central Unit to the recording equipment's recording input.

There are 2 types of recording output terminals: a phone jack and RCA jacks. Select either type of jack according to recording equipment to be connected.

Note

Prepare the connection cables separately.

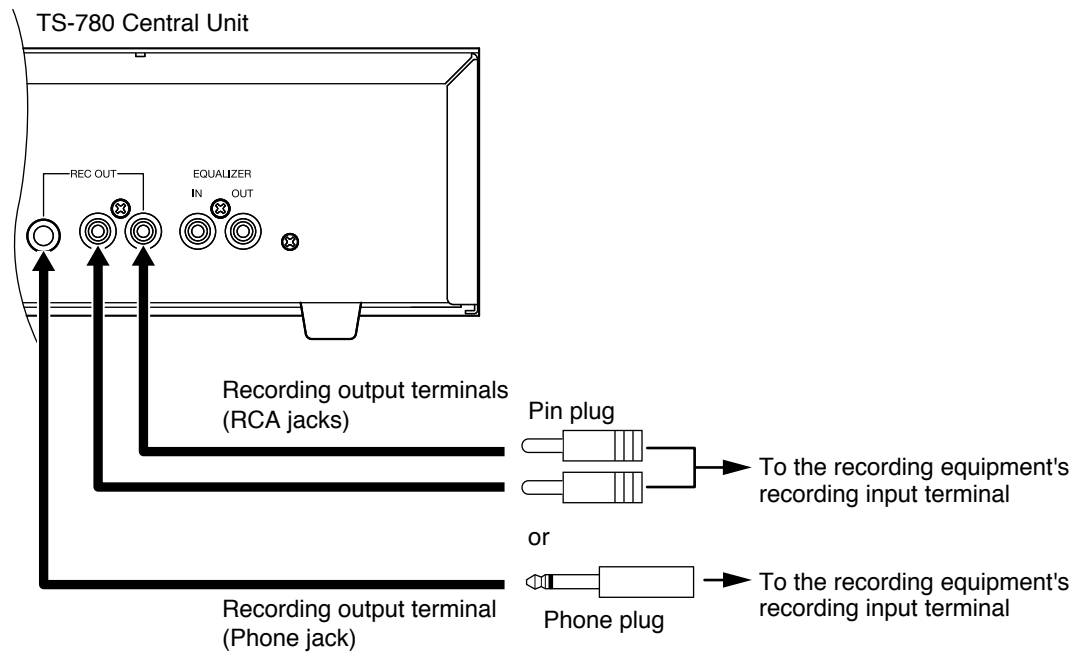

Step 2. Connect a set of headphones into the recording equipment's monitor output to confirm that the contents of the conference are being recorded correctly.

If the recording equipment is equipped with a recording level control, adjust it to an appropriate recording level.

For use of recording equipment, refer to the instruction manual supplied with the equipment.

7.2.2. Recording with the Chairman Unit or Delegate Unit

Using the Recording/Headphones Output terminal on the side panel, recordings can be made in the same manner as for the Central unit.

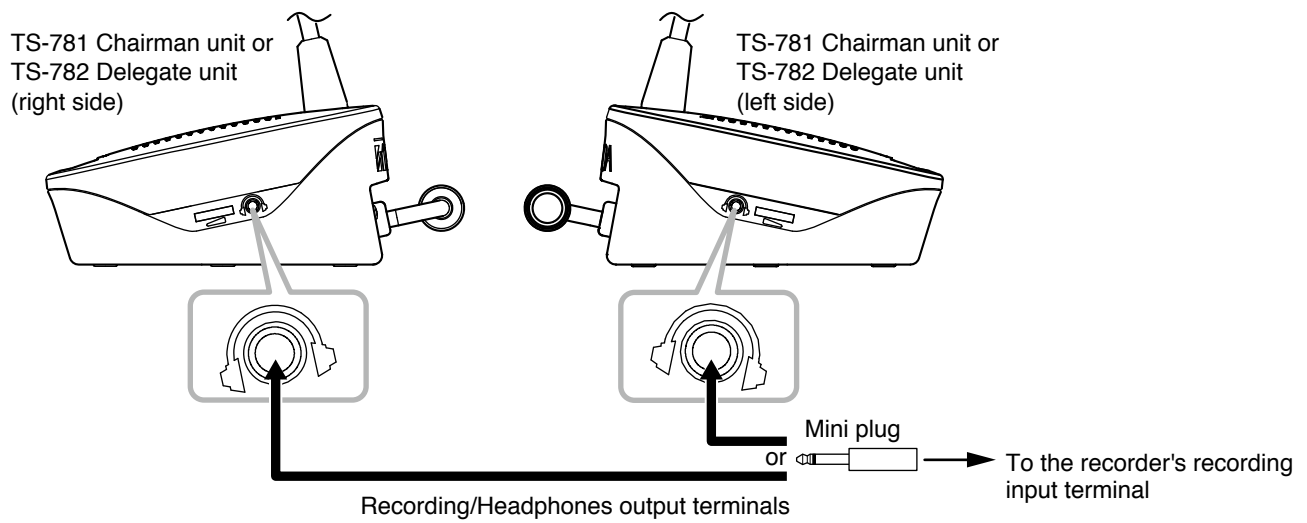

Notes

- If either of Recording/Headphones jacks on the right and left sides is used, no sound is output from the unit's speaker.
- Sound volume from the recording output of the Chairman and Delegate units can be adjusted using the Central unit's Line Volume control. Setting the line volume control to the minimum position makes it impossible to record from the recording output of the Chairman and Delegate units. When wishing to record conference contents without muting the sound output from the Chairman and Delegate unit speakers, use the Central unit's Recording Output terminals.

8. INSTALLATION AND CONNECTION

8.1. Installation Procedures

Basic System Installation

(1 Central unit and up to 64 Delegate units)

1. Connect the Chairman/Delegate units to the Central unit (see p. 44).

2. Perform function settings for the Central unit, and volume adjustment, etc. for the Chairman/Delegate units (see p. 46).

If using multiple Central units:

(Up to 3 Central Units and up to 192 conference units)

3. Repeat Steps 1 and 2 above for each Central unit's connections and settings (see p. 48).

4. Make connections between Central units (see p. 48).

8.2. Connection Example

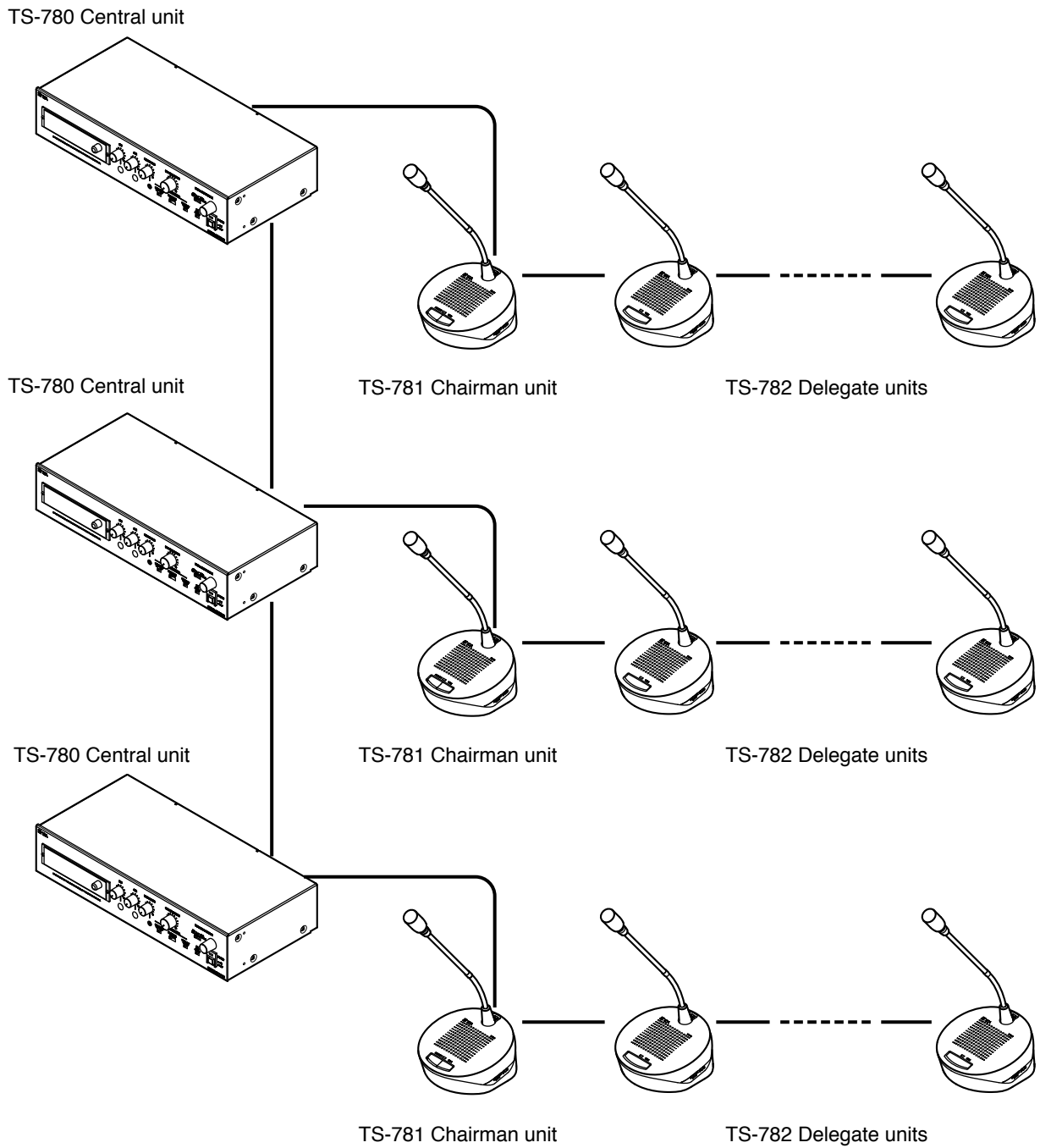

8.3. Basic System Installation and Adjustment

This section explains how to install and adjust a basic system comprised of 1 Central Unit and Chairman and Delegate units.

8.3.1. Connecting the Chairman and Delegate units to the Central unit

Step 1. Connect either the TS-773 or TS-774 Microphone to the TS-781 Chairman unit and TS-782 Delegate unit.

TS-773: Standard gooseneck microphone
 TS-774: Long gooseneck microphone

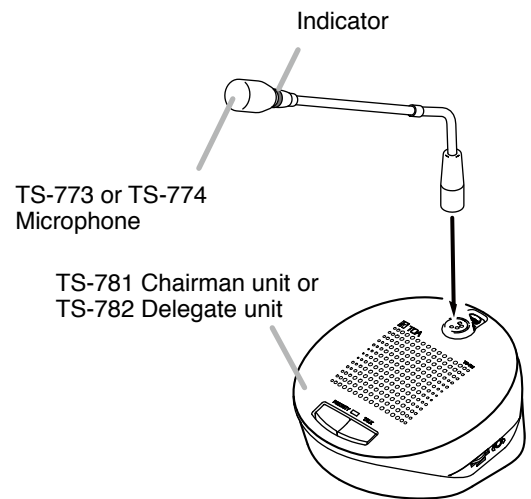

Step 2. Connect the TS-781 Chairman unit and TS-782 Delegate unit to the TS-780 Central unit. When installing, keep conference units 1.5 – 2 m away from each other. If distances exceed 2 m, use YR-780-2M (2 m) or YR-780-10M (10 m) extension cords. Up to 32 conference units can be connected per line (line 1 and 2) of the central unit. Ensure that the total length of connection cables between the Central unit and the last conference unit is less than 100 m.

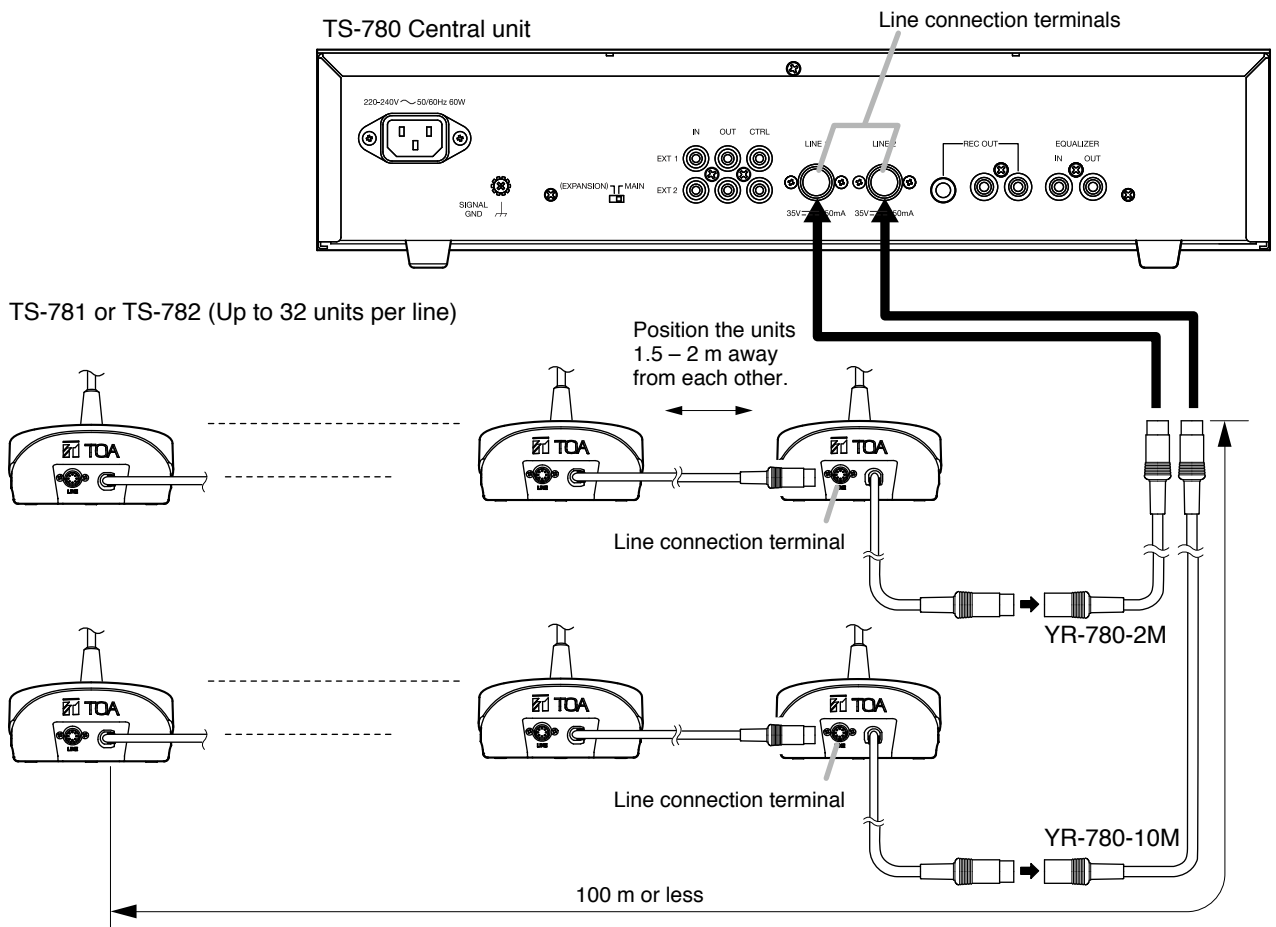

Step 3. Set the Test switch on the front panel of the Central unit to ON. (Test mode)

The Test indicator lights together with the conference unit's Microphone in-use indicator and the indicator on the microphone.

Note that as the number of connected conference units increases, several seconds may elapse before the indicators light.

When all indicators for the installed conference units light, this completes connection confirmation. In this event, if the indicators of a certain conference unit do not light, check the connections of the microphone and those between the Central unit and conference units.

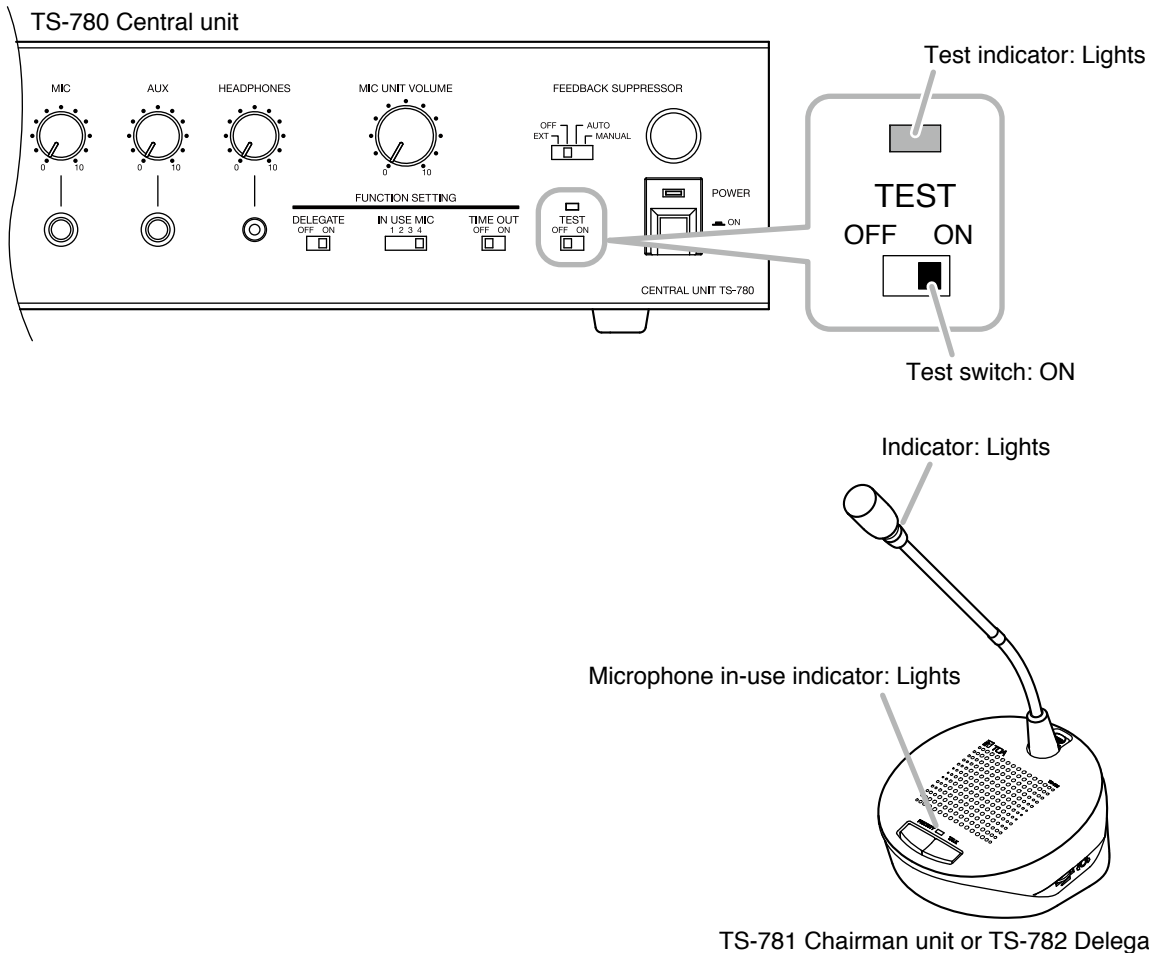

Step 4. After completing the test, shift the Central unit's Test switch back to the OFF position. (Test mode off)

Note that as the number of connected conference units increases, several seconds may elapse before the indicators go off.

8.3.2. Setting functions and adjusting Chairman/Delegate units sound output volume

Step 5. Set the number of simultaneously operable Delegate units using the In-use delegate unit number selector on the front panel of the Central unit.
For details, refer to p. 10.

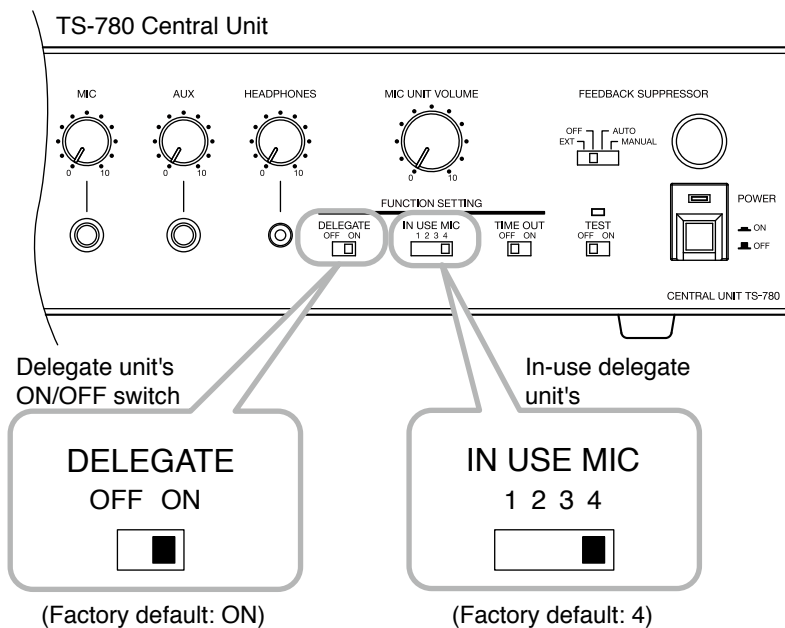

Step 6. Adjust the sound volume of the Chairman/Delegate units.
Press the Talk key on both the Delegate unit in the number set in Step 5 and the Chairman unit to turn on their microphone. Speaking into the microphone, adjust the volume to an appropriate level using the Central unit's Conference Unit Volume control.

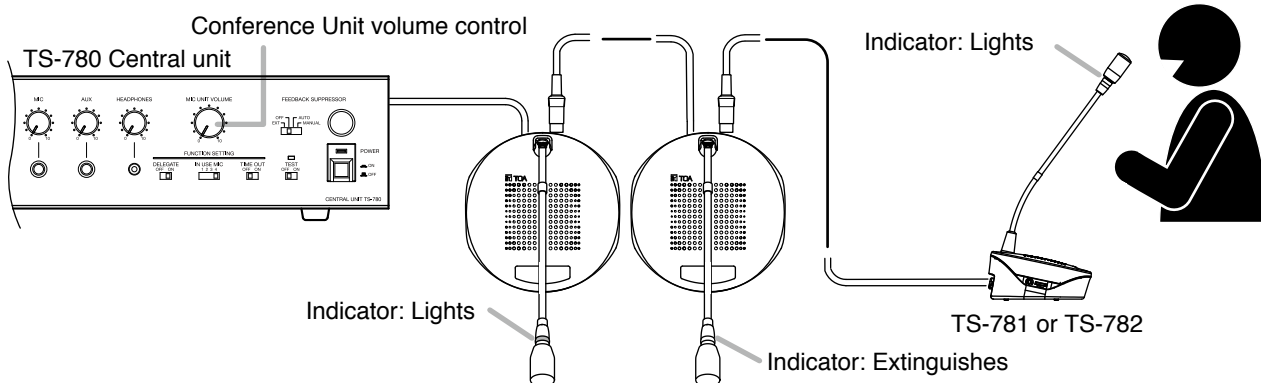

Step 7. Confirm that no acoustic feedback is generated from any microphone to be used.
If acoustic feedback occurs, widen the distance between conference units or turn down the line volume in order to prevent feedback.
When acoustic feedback still occurs, take measures to prevent the feedback using a built-in FBS function or an external graphic equalizer. (Refer to p. 12 "FBS (Feedback Suppressor) Function.")

Step 8. Set the Automatic Mic-Off function* to ON, as required, using the Automatic Mic-Off setting switch on the front panel of the Central unit.

* This function automatically turns off the microphone if not used for 30 seconds (see p. 11).

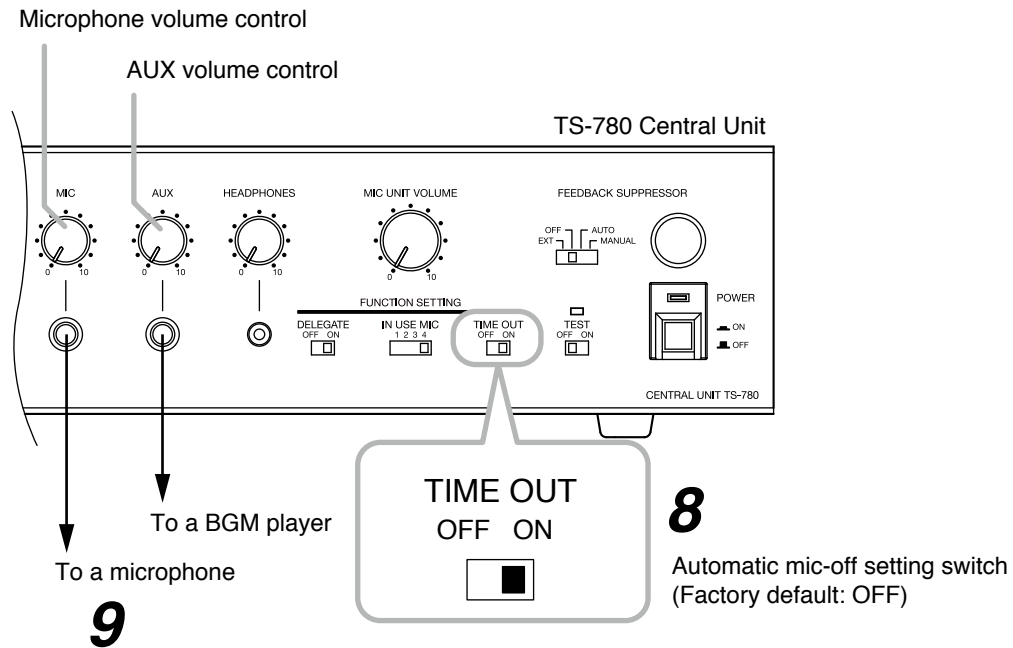

Step 9. (When using a microphone or BGM player)

Connect it to the Central unit and adjust its sound volume.

Connect a microphone to the Microphone input terminal and a BGM player to the AUX input terminal as shown above.

Adjust the volume to an appropriate level using the corresponding volume control.

Step 10. (When recording conference contents)

Use the built-in MP3 recorder, or an external recording equipment if necessary. To use the external recording equipment, connect its recording input terminal to the Central unit's Recording output terminal or the Chairman/Delegate unit's Recording/Headphones output terminal.

For details, refer to p. 40.

[When you use an external recording equipment]

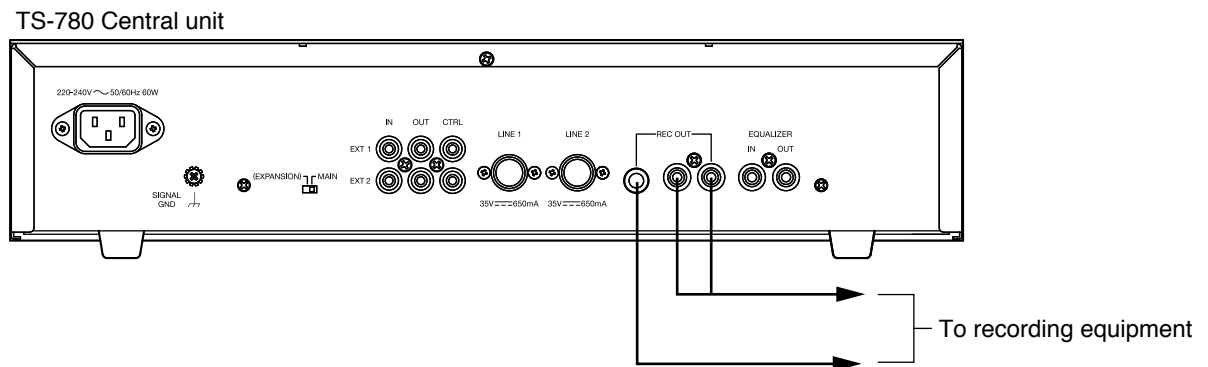

9. IF USING MULTIPLE CENTRAL UNITS

Up to 3 Central Units and up to 192 conference units can be connected per system.

Note

Match the setting for Automatic Mic-off function among Central units. If differently set, these function will not work correctly.

Step 1. Perform connections and adjustments for each Central unit.
Follow Steps 1 – 10 on pages p. 44 – p. 47 for each Central unit.

Step 2. Set the Central unit's rear-mounted Expansion switch.
Set the Expansion switch of one of the connected Central units to MAIN, and the remaining Central units to EXPANSION.

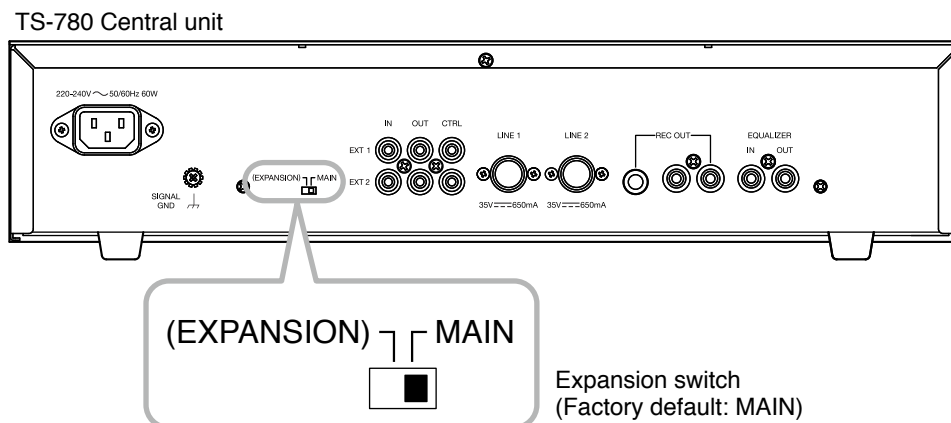

Step 3. Make connections between Central units.

Connect the Expansion IN-OUT terminals mutually between Central units, as shown below. Note that the CTRL terminal of the Main Central unit must be connected directly to each CTRL terminal of the Expansion Central unit(s) using a single line.

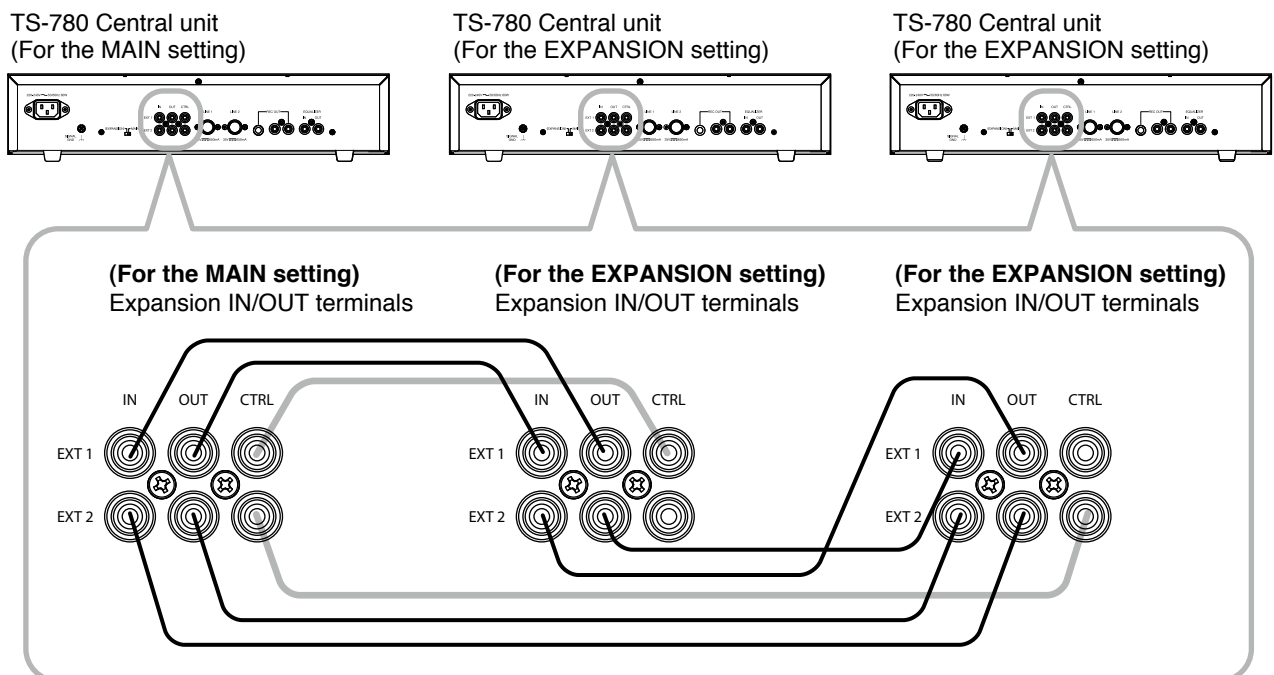

Note

Because no cables are supplied for connection between Central units, prepare them separately.

Applicable connector: RCA plug

Applicable cable: Single-core shielded cable

Step 4. Set the Central unit's functions as follows:

- Delegate unit ON/OFF switch and In-use delegate unit number selector
Only set both switch and selector of the MAIN Central unit. (This setting takes effect regardless of the switch settings of the other EXPANSION Central Units.)
- Automatic Mic-Off Setting Switch
Perform the same setting for all connected Central units.

10. IF MOUNTING A CENTRAL UNIT IN A RACK

Step 1. Remove the rubber feet from the bottom of the unit.

Step 2. Mount the unit in a rack using the optional MB-23B Rack mounting bracket.

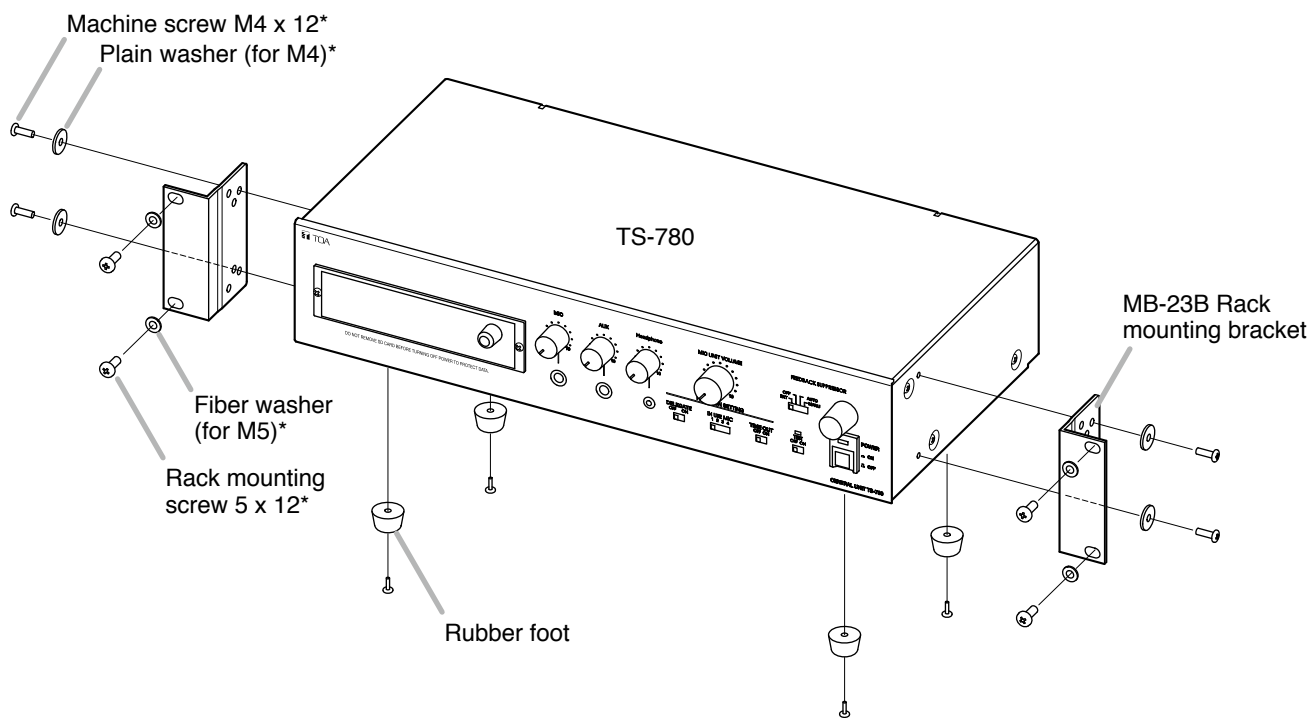

* Supplied with the MB-23B

11. SPECIFICATIONS

11.1. TS-780 Central Unit

Power Source	220 – 240 V AC, 50/60 Hz
Power Consumption	60 W
Rated Output	36 V DC, 650 mA x 2
Input	MIC: –60 dB*, 600 Ω, unbalanced, phone jack AUX: –20 dB*, 10 kΩ, unbalanced, phone jack
Output	Recording: –20 dB*, 10 kΩ, unbalanced, phone jack, pin jack x 2 Headphones: Mini jack
Equalizer Insertion Input Terminals	Input: 0 dB*, 10 kΩ, pin jack Output: 0 dB*, 10 kΩ, pin jack
Expansion Input and Output Terminal	Input: 0 dB*, 10 kΩ, unbalanced, pin jack x 2 Output: 0 dB*, 10 kΩ, unbalanced, pin jack x 2 Control: 10 kΩ or more, voltage output, pin jack x 2
Control	Priority speech chime: Operation of TS-781's priority key activates a single-tone chime. Speaker restriction: Number of simultaneously-usable TS-782s can be set to 0 – 4. Automatic Mic-off Function: OFF, 30 s (selectable) Feedback Suppressor function (FBS): EXT, OFF, AUTO, MANUAL mode (selectable) MP3 recording and playback
Operating Temperature	0 to 40°C
Operating Humidity	90 % RH or less (no condensation)
Finish	Panel: Aluminum, black, 30% gloss, paint Case: Steel plate, black, 30% gloss, paint
Dimensions	420 (w) x 96.1 (h) x 226.2 (d) mm
Weight	3 kg

* 0 dB = 1 V

Note: The design and specifications are subject to change without notice for improvement.

• Accessory

Power cord (2 m) 1

• Optional products

Extension cord: YR-780-2M, YR-780-10M

Rack mounting bracket: MB-23B

MPEG Layer-3 audio coding technology licensed from Fraunhofer IIS and Thomson.

Supply of this product does not convey a license nor imply any right to distribute MPEG Layer-3 compliant content created with this product in revenue-generating broadcast systems (terrestrial, satellite, cable and/or other distribution channels), streaming applications (via Internet, intranets and/or other networks), other content distribution systems (pay-audio or audio-on-demand applications and the like) or on physical media (compact discs, digital versatile discs, semiconductor chips, hard drives, memory cards and the like).

An independent license for such use is required. For details, please visit <http://mp3licensing.com>.

11.2. TS-781 Chairman Unit and TS-782 Delegate Unit

Power Source	36 V DC, 30 mA or less (supplied from the Central Unit TS-780)
Output	Headphones/Recording: 32 Ω (headphones)/10 kΩ, -20 dB* (recording), unbalanced, mini jack (with Volume control) x 2 Internal Speaker: 130 Ω, 200 mW (with Volume control)
Control	Talk key: Microphone, speaker on-off control by talk key Priority key (TS-781 only): Microphone, speaker on-off, other microphone cutoff, and single-tone chime activation
Operating Temperature	0 to 40°C
Operating Humidity	90 % RH or less (no condensation)
Finish	Upper case: ABS resin, silver metallic, paint Lower case: ABS resin, black
Dimensions	145.3 (w) x 70.7 (h) x 150.5 (d) mm
Weight	800 g

* 0 dB = 1 V

Note: The design and specifications are subject to change without notice for improvement.

• Optional products

Extension cord: YR-780-2M, YR-780-10M

Microphone: TS-773 (standard), TS-774 (long) (select either one)

11.3. TS-773 and TS-774 Microphones

Model No.	TS-773	TS-774
Type	Electret condenser microphone	
Directivity	Unidirectional	
Rated Impedance	1.8 kΩ	
Rated Sensitivity	-37 dB (1 kHz, 0 dB = 1 V/Pa)	
LED Indicator	Speech Indicator (ring type)	
Frequency Response	100 Hz – 13 kHz	
Output Connector	Combined type of XLR-4-32	
Finish	Gooseneck: Stainless steel, black Other: ABS resin, black	
Length	368 mm	518 mm
Weight	90 g	105 g
Applicable Unit (Option)	TS-781 Chairman unit, TS-782 Delegate unit	

Note: The design and specifications are subject to change without notice for improvement.

11.4. YR-780-2M 2 m Extension Cord and YR-780-10M 10 m Extension Cord

Model No.	YR-780-2M	YR-780-10M
Cable Length	2 m	10 m
Connector	8 pins DIN socket (going to the unit's base) 1 8 pins DIN plug (going to the cord) 1	

Note: The design and specifications are subject to change without notice for improvement.

Traceability Information for Europe

Manufacturer:
TOA Corporation
7-2-1, Minatojima-Nakamachi, Chuo-ku, Kobe, Hyogo,
Japan

Authorized representative:
TOA Electronics Europe GmbH
Suederstrasse 282, 20537 Hamburg,
Germany

URL: <http://www.toa.jp/>